

Multiple Organizational Identities and Change in Ambivalence: The Case of a Chinese Acquisition in Europe

Abstract

Purpose

Building on social identity theory, the purpose of this paper is to examine how European managers construct their multiple identities after being acquired by a Chinese firm, and to determine the key factors contributing to the changing dynamics of multiple organizational identities.

Methodology

The paper presents a qualitative, single case study of a Chinese acquisition of a European manufacturing firm at two points in time.

Findings

We find that multiple identities initially trigger ambivalence towards the acquisition, but over time, the ambivalence diminishes. The reduction of ambivalence results from concurrent integration and separation: ambivalent boundary spanning identity separates positive identities from negative ones, and integration interventions foster the development of a new, shared identity.

Research implications

We shed light on how ambivalence towards the acquisition changes overtime through dynamic interactions between multiple identities.

Originality/value

The findings reveal that organizational identity change is facilitated by the aligning of a post-merger identity with the acquired organization's historical identity, and by creating an ambivalent boundary spanning identity.

Key words: Acquisitions, ambivalence, China, identity change, multiple identities

Introduction

Organizational identity construction processes have been extensively investigated in management and social psychology literature. There is growing evidence that identity construction processes might be particularly challenging when multiple organizational identities are involved. On the one hand, multiple identities might pose challenges such as conflict and role overload (Pratt and Rafaeli, 1997). On the other hand, multiple identities can open up opportunities by, for example, enhancing an organization's competitive advantage (Irwin et al., 2018) and responsiveness to complex external environments (Ashforth and Mael, 1996). Lastly, multiple identities might also trigger ambivalence, defined as "simultaneously positive and negative orientations toward an object" (Ashforth et al., 2014a, p. 1454), within organizations. However, the process of *how* multiple organizational identities are constructed in cross-border M&As remains under-investigated (Sarala et al., 2019).

To deepen understanding of this topic, we collected qualitative process data in the context of Chinese acquisitions in Europe. Unsurprisingly, scholars are increasingly interested in Chinese acquisitions, but the process of how multiple organizational identities are constructed in this emerging and relevant context has not been explored in depth. In this study, we therefore will focus on the following research questions: i) how do members of a European organization construct their multiple identities over time after being acquired by a Chinese organization? and ii) what are the key factors in the changing dynamics of multiple organizational identities?

The qualitative, in-depth single case study of a Chinese takeover of a European manufacturing firm presented in this paper will address these questions. Our inductive data analysis reveals that multiple identities trigger ambivalence towards the acquisition in European managers. However, we also find that this ambivalence decreases over time, resulting in an increased willingness to collaborate in Sino-Western teams. Between Time 1 (T1) and Time 2 (T2), European managers responded to the ambivalence by a concurrent identity separation and identity integration: a newly constructed identity by the Chinese Owner was viewed to separate the positive identity from the negative one, and the concurrent integration of positive and ambivalent identities fostered the development of a shared identity. Our data also reveals the importance of historical identities and a meaningful interplay between a valued historical identity and a disidentification from the pre-identity,

i.e., identity of the previous parent organization. Consequently, at T2, European managers demonstrated a positive orientation toward the acquisition.

Theoretical Background

Organizational identity and identification are grounded in the social identity approach. Social identity theory helps explain social behaviour wherein individuals are not solely acting on the basis of their personal identities but as members of their group(s) in relation to members of other groups (Tajfel and Turner, 1986; van Dick et al., 2004). Self-categorization theory explains how and when people will define themselves as group members, and examines the impact of this variability on self-perception (“I” vs. “we”) to better understand individual and group behavior (Turner, 1985; Turner et al., 1987). Based on the social identity approach, “organizational identity relates to stereotypic attributes of an organization that are conferred upon it by those for whom the organization is relevant and meaningful.” (Haslam et al., 2003, p. 360). The related concept of organizational identification describes the strength of the relationship between the individual organizational member and the organization.

Organizational identification refers to “the extent to which people define themselves as members of a particular group or organization”, and “indicates whether people engage in a process of self-stereotyping whereby their behaviour is oriented towards, and structured by, the content of that group or organization’s defining characteristics, norms and values” (Haslam et al., 2003, p. 360).

Organizational Identity Change in Cross-Border M&As

Organizational identity change in M&As has received significant attention in organizational studies (Giessner et al., 2011; Gioia et al., 2013; Wei and Clegg, 2018). There is empirical evidence showing that changing organizational identity is often not easy for employees from both acquiring and acquired organizations. For example, in a qualitative study Wei and Clegg (2018) found that identity change takes place gradually throughout the post-merger integration: First, employees might show resistance to the identity change, and only with appropriate managerial interventions, might they accept the change over time. Interestingly, employees might resist identity change even if changes are minor, as demonstrated in a qualitative, embedded case study in Mexico (Lupina-Wegener et al., 2015). Moreover, in the qualitative case study of a Finish-Swedish merger, Vaara et al. (2003) explain that the identity change process is difficult because of employees’ attachment to their pre-organizational identities and the stereotypical negative thinking of their new colleagues. In a qualitative case study of a German and Italian/ Swiss merger, De Bernardis and Giustiniano

(2015) found that pre-merger identities can co-exist while a superordinate identity is shared by members of acquiring and acquired organizations. Indeed, multiple identity construction involves a complex interplay of pre- and post-merger identities which might imply both challenges and opportunities in the post-merger organization (Sarala et al., 2019). Despite relevant insights into the complexity of identity change, how and under what conditions multiple identities can be constructed, co-exist or changed in cross-border M&As remains underexplored.

Multiple Identities and Ambivalence in M&As

Although underexplored in cross-border contexts, complexity of multiple identity construction in organizations has received a fair amount of scholarly attention. Ashforth and Johnson (2001) argue that identities may exist at different levels of abstraction, ranging from higher (organization, division) to lower order identities (workgroup, job) or employees' personal identities (e.g., their careers). There is some evidence that multiple identities might result in identity conflict, ambiguity (Corley and Gioia, 2004) and role overload (Pratt and Rafaeli, 1997). On the positive side, multiple identities can be combined into a holistic identity, which has benefits for organizations such as enhanced integrative capacity to respond to complex external environments (Ashforth et al., 2016), expectations of multiple internal stakeholders (Ashforth and Mael, 1996), and increased competitive advantage (Irwin et al., 2018). Considering both opportunities and challenges in organizations, we argue that multiple identities can trigger "simultaneously positive and negative orientations" toward an acquisition (Ashforth et al. 2014, p. 1454). Similarly, identity change might result in ambivalence rather than resistance per se (Piderit, 2000). To our knowledge, the only study on M&As that addressed ambivalence is a qualitative, longitudinal multiple case investigation conducted by Chreim and Tafaghod (2012) who reveal that in a post-merger organization contradictory frames co-exist i.e. acquiring and acquired managers are embedded in different structural, temporal and experiential foci and thus, their efforts to mitigate ambiguity i.e. might lead to ambivalence towards the acquisition.

We argue that the potential ambivalence towards an acquisition or towards change triggered by multiple organizational identities is heightened by the fact that the relationship between organizational members and their organization may take different forms. According to the expanded model of organizational identification (Kreiner and Ashforth, 2004, p. 18), there are four forms of identification. In addition to identification in the traditional sense (i.e., perceived overlap between the self and the organization), the expanded model proposes

disidentification, ambivalent identification, and neutral identification as distinct ways of relating to an organization. Disidentification refers to an active separation from the organization, implying negative evaluations. Neutral identification refers to a state of indifference toward the organization. Finally, ambivalent identification is a combination of identification and disidentification, occurring, for instance, when an employee is proud of some aspects of the organization but embarrassed by others. Ambivalent identification, with a single identity, is distinctive from *ambivalence* in an organization which results from salient multiple identities, especially if they are perceived as being opposed Ashforth et al. (2014). Ambivalence is distinctive from ambiguity which is the result of the presence of multiple interpretations and a lack of clarity (Weick, 1995).

Despite these conceptual insights, we argue that there is need to investigate multiple identities together with the four types of identification. Moreover, triggers of ambivalence and responses of acquired managers remain empirically unknown (Chreim and Tafaghod, 2012)

Context of Chinese Acquisitions in Western Markets

In this paper, we will focus on the process of *how* multiple organizational identities are constructed in Chinese acquisitions in Europe, an under-investigated phenomenon from a process perspective, and to which the extant literature on M&As might not apply (Deng, 2013). This is due to two reasons. First, Chinese acquisitions represent an intriguing context for the study of organizational identity and identification due to the large cultural differences between the Chinese acquirers and their Western partners (Cheng, 2014). Such differences may stimulate value creation, but also may be the source of conflicts and misunderstandings (Li and Wan, 2016). Second, Chinese acquisitions are different from Western acquisitions in terms of the autonomy granted to the acquired organization. There is indeed evidence that Chinese firms often acquire Western businesses which are on the brink of bankruptcy (Rui and Yip, 2008), and their motive is frequently to access strategic assets in developed economies through a limited integration and a high autonomy granted to the members of the acquired firm (Zheng et al., 2016). A multiple case study conducted by Klossek, Linke and Nippa (2012) confirms that Chinese acquirers such as Beijing's number one firm Lenovo and the Shangong Group, grant autonomy to the acquired firms. To this end, they set up a dual leadership, split control, and share responsibilities between Chinese and German employees and the top management teams.

Despite the granting of autonomy, and in the light of cultural differences, there is empirical evidence that Western members of the acquired firm show resistance to implementing organizational practices of a Chinese acquirer and tend to be less committed to the Chinese acquirer than the other way around (Yildiz and Fey, 2016). Moreover, a qualitative case study of the acquisition of IBM's personal computer division by Lenovo reveals threats and fears present in Western media accounts (Riad et al., 2012). Last but not least, insights into multiple identities construction in Chinese acquisitions are particularly relevant as China emerges as a major player in cross-border M&As, with the number of China's outbound acquisitions nearly 3.5 times higher in 2016 compared to the preceding year (PwC Report, 2017).

Methodology

In this paper, we investigate the process of multiple organizational identity construction as experienced by members of a European organization acquired by a Chinese MNC. We used a qualitative case study design as this approach is appropriate when investigating complicated organizational phenomena of multiple identities through a holistic understanding of organizational events in their work settings. Single-case studies are particularly suitable in research of revelatory settings as they provide unique insights into how certain circumstances change over time and lead to certain consequences (Yin, 2009). Indeed, qualitative methods are widely appreciated for theorizing rich process data, and staying close to the original data ensures accuracy of data analysis (Langley, 1999). The main research questions guiding this project are broadly formulated to allow for emergent theory building. The research questions are as follows: i) "how are multiple organizational identities constructed over time in a European organization after an acquisition by a Chinese organization?" and ii) what are the key factors in the changing dynamics of multiple organizational identities?

Research Setting

Alpha-Owner is a multidivisional Chinese holding founded after China's accession into the World Trade Organization in 2001. Alpha-Prod is a key division focused on the manufacturing of low-end machineries. After many boom years, sales of Alpha-Prod products began to decline as their quality no longer met the increasingly demanding expectations of Chinese customers. In order to better satisfy home market customers and enter the global market, Alpha-Owner sought to improve Alpha-Prod's manufacturing, technology and managerial know-how. To this end, it acquired Beta-West, a boutique

manufacturer with state-of-the-art capacities. Prior to its acquisition by Alpha-Owner, Beta-West was owned by Gamma, an MNC based in another (Western) country. Beta-West was on the brink of bankruptcy under Gamma, which Beta employees attributed to the insufficient resources provided by Gamma for R&D. Beta-West thus viewed the acquisition by Alpha-Owner as an opportunity to access the growing Chinese market and to benefit from Alpha's financial support for the development of new products. Before being owned by Gamma, Beta-West was an independent company. Table 1 displays the chronology of events.

INSERT TABLE 1 ABOUT HERE

The post-merger structure was as follows: i) Alpha-Owner acquired Beta-West; ii) Sino-Beta was created by Alpha-Owner in China to support Beta's business in China; iii) Alpha-Prod was a sister organization for Beta. After the acquisition, Beta-West became the Head Office of Sino-Beta, separated from Alpha-Prod. AB-Tech was created at a later stage in the post-merger integration in the home town of Beta-West. It was intended to serve as a new R&D Center of Alpha-Prod to foster new R&D developments between Alpha-Prod and Beta. Figures 1 and 2 display the interorganizational collaboration from T1 to T2. Although AB-Tech was created at T1, only at T2 did it play an important role in how employees made sense of the changes that happened between T1 and T2. Thus, we include AB-Tech in Figure 2, not in Figure 1.

INSERT FIGURE 1 ABOUT HERE

INSERT FIGURE 2 ABOUT HERE

Data Collection

Interviewees were chosen using purposeful sampling (Suri, 2011). We interviewed informants in the purchasing unit who interacted with Chinese engineers from Sino-Beta and from Alpha-Prod. Their reason for collaborating was shared sourcing and economies of scale. We stopped collecting data once we had obtained theoretical saturation (Glaser and Strauss, 1967) i.e., there were no new conceptual categories or insights from new informants or archival data. Table 2 provides an overview of the interviewees, they are purchasing managers whose aims were to decrease production costs in synergies with Sino-Beta and Alpha-Prod. In order to guarantee confidentiality of the studied organizations, we cannot provide further details of the sample.

We conducted interviews in respectively years 3 and 5 following the acquisition, referring to temporal bracketing strategy to account for clear temporal break points to obtain distinctive units of analysis (Langley, 1999; Pettigrew, 1990). Time one (T1) interviews were conducted when the Chinese subsidiary of Beta began to autonomously run the business in China (see decentralization, production sites, Table 1) with close collaboration between Sino-Beta and Beta-West managers. We continued two years later with time two (T2) interviews, a period characterized by a successful completion of joint projects by Beta-West and Sino-Beta managers.

INSERT TABLE 2 ABOUT HERE

We obtained access to the case through a senior manager from Beta-West who, after exchanges with one of the authors, invited the research team to conduct the interviews. We interviewed European managers across different levels at Beta-West or who were on expatriate assignments at Sino-Beta. At T1, we conducted 15 interviews, and at T2, 20 interviews, each interview lasting on average 60 minutes. Four of the T2 interviewees also had been interviewed at T1, whereas the others were either not available for the meeting, or had been relocated to competitors or abroad within Beta. Moreover, at T2 we included managers who joined Beta-West after the acquisition by Alpha to consider the human resource mobility between T1 and T2, wherein the number of employees at Beta-West significantly increased. All but three interviews at T2 were conducted in English, with the remaining three conducted in Chinese with local Beta-West employees. The interview guide consisted of open-ended questions falling into three sections: culture change after the merger, multiple identities (type, degree, status), and interactions with stakeholders (distant and local environments). We did not include retrospective questions, but interviewees often made links to the past in light of their current experiences of the acquisition. All interviews were recorded and subsequently transcribed. Detailed notes were taken directly after each interview and after informal conversations. In addition to the interviews, we relied on additional sources of information to triangulate the interview analysis (Yin, 2017) and ensure internal validity (Popper, 2005). We analysed the archived data from articles published in business press, or from Beta-West intranet. In addition, we held numerous off-record discussions with three interviewees, two of whom were interviewed in both T1 and T2.

Data Analysis

We followed the qualitative grounded-theory approach to theorize from process data in order to identify generative mechanisms. A process is an ongoing interaction that responds to situations or problems, often with the target of reaching a goal or handling a problem, and process data can offer many opportunities for grounded theorizing (Corbin and Strauss, 2008; Langley, 1999). We therefore looked for circumstances that may help shape interactions and subsequent consequences. Our data analysis involved the following three steps:

We began with a first-order analysis by reviewing interview transcripts and archival data (Corley and Gioia, 2004) while looking for circumstance (multiple identities), experience of interactions among Chinese and European managers, culture change and outcomes (collaboration as consequences). We identified initial concepts in the data and grouped them into categories (first-order coding). Initially, codes had purely descriptive words and lines to keep them as close as possible to the informants' original language. For example, "Alpha-Prod has terrible products" and "We don't know about Alpha-Prod". Subsequently, constant comparative methods were adopted. The codes were compared among the informants to reveal similarities and analytic differences among the codes. We then categorized new incidents into existent codes or created a new code if analytic differences existed.

In the second step, we proceeded with second-level coding (axial coding), which was the integration of categories and their properties into higher order themes (Corbin and Strauss, 2008). Using constant comparative methods, we compared across codes, generating themes from first-order codes. For instance, we compared across codes from different interviewees, and we generated the theme "Alpha-Owner identity" from the first-order codes like "Alpha-Owner was *quite a small company*" and "Alpha-Owner was a small organization led by a powerful leader". Interestingly, when we asked questions about organizational identity (e.g., "Please describe Alpha-Owner with three words, and why you chose them?"), we also received answers relating to positive or negative evaluations of the interviewees' group membership (e.g., "I thought Alpha-Owner was *quite a small company* in China...", "...most of the colleagues *are not so happy* about the acquisition by Alpha-Owner"). We thus further coded for different organizational identities, referring to the expanded model of organizational identification (Kreiner and Ashforth, 2004). Specifically, in the data analysis, we inferred different forms of identification towards entities which were related to the Alpha-Beta acquisition. We assigned a positive value for identification, a negative value for disidentification, both positive and negative values for an ambivalent identification and a neutral value for neutral identification. Specifically, at T1 once we had coded the negative

and positive forms of identification, which co-existed, we saw that ambivalence towards the acquisition had emerged.

At T2, we observed a decreased ambivalence as positive forms of identification replaced those which were negative or ambivalent at T1. Specifically, at T1 positive and negative forms of identification co-existed, which resulted in high ambivalence towards the acquisition as illustrated in Figure 3. As stated in the literature review ambivalent identification with single identity foci is distinctive from ambivalence in an organization which results from multiple, positive and negative identities. Then at T2, with the disappearing of negative forms of identification, ambivalence towards the acquisition decreased as presented in Figure 4.

INSERT FIGURE 3 ABOUT HERE

INSERT FIGURE 4 ABOUT HERE

Finally, we conducted third-level coding (theoretical coding) by accessing the semantic relationships among different themes (Glaser and Strauss, 1967). Emerging relationships among codes and theoretical linking were recorded in memos. We collected similar themes into several dimensions that constituted our emergent framework. Specifically, we arrived at the grounded theory model by using iterative comparisons of the context of changes (change in ambivalence, e.g., high ambivalence at T1 and decreased ambivalence at T2), circumstances shaping the changes (multiple identities) and consequence of changes (collaborations). how do members of a European organization construct, respectively, and demonstrates that negative, positive and ambivalent forms of identification co-existed at T1, which we refer to as “multiple opposite identities”. Those salient identities were perceived to be in opposition, leading to a high ambivalence towards an acquisition. However, at T2, positive identities were integrated and the negative identity was separated which led to a decrease in ambivalence towards the acquisition.

INSERT TABLE 3 ABOUT HERE

Intermediary results at T1 and T2 were discussed with our key informant who introduced us to the acquisition and the top management team at Beta-West. In order to ensure construct

validity, we analysed the archive data as an important source for understanding events and mitigating possible “retrospective bias” which might occur in the interviews (Miles et al., 1994). Moreover, we analysed numerous articles on this acquisition published in the business press. We had access to the intranet of the company; thus we analysed available internal publications on the acquisition. In addition, we conducted ‘member checks with our main informants’ to ensure that our emerging analytical pattern matched how the acquisition was actually experienced (Clark et al., 2010); for example, we conducted multiple off-record discussions with three interviewees, two of whom were interviewed at both T1 and T2. We also calculated the frequency of the codes which we included in Table 3. We found at least 75% agreement among interviewees in each code. Finally, for internal consistency (Popper, 2005) the four co-authors had seven meetings over 24 months starting with the T2 data collection to jointly brainstorm on the emerging patterns and causal relationships in light of the social identity theory.

Results

This section presents our findings regarding identity construction at Time 1 and Time 2. For each point in time, we first describe the organizational context relevant for the findings that emerged.

Time 1

Organizational Context

At the beginning of the acquisition, Sino-Beta was built as a subsidiary of Beta-West in China. Some experts from Beta-West were sent to China to share their know-how. At the same time, Chinese colleagues in Sino-Beta collaborated with Beta-West on building factories and commercializing Beta products in China. A “manager match” project was started to connect managers from Beta-West and Sino-Beta. In the project, every director from Beta-West had a match director from Sino-Beta. Following decentralization, employees from Sino-Beta no longer needed to report to Beta-West managers. Western managers worked with Sino-Best without any cultural preparation or assistance in human integration. Alpha-Prod was a key division of Alpha-Owner, but it was different from Sino-Beta, the latter working on high-end machines whereas Alpha-Prod focused on manufacturing low-end machines. Alpha-Owner therefore aimed to improve manufacturing, technology and managerial know-how at Alpha-Prod.

Multiple Opposite identities

Several identities were salient to our interview partners which we shall describe in turn. Table 3 illustrates the changing dynamics in multiple identities, together with representative quotes.

(1) *Beta-West*. Western managers had a salient Best-West identity which, after the acquisition, was viewed as being independent again (compared to the time when owned by Gamma). Beta-West's identity was viewed as a traditional but premium, high quality manufacturer whose state-of-the-art technical expertise had developed through decades of experience. Quality had been at the heart of Beta-West since its conception and had special meaning for the employees. For example, quality signified care for the customers and it was viewed as being reflected in the finest products, their unique functional design and the personal convictions of the employees. Interviewees claimed there was a "Beta-West spirit" and they were proud of Beta-West DNA. One of many different testimonies illustrates how quality was at the heart of Beta-West's identity:

It's quality in the sense of durability. It's not a quality in the sense of a "jewel effect". Do you understand what I mean? The quality in the sense of that you buy a product which won't break down...but, it is not like jewellery...like a nice watch.... I think it is still we have, what we call "Beta spirit". So, all people who are working here are really fighting for Beta and that hasn't changed since we were sold to Alpha. And also during the period when we belonged to Gamma, we had the "Beta spirit". Even before that, when we belonged to [mentions the owner, prior to Gamma] ... still we had the "Beta spirit". It is something we want to keep and I am sure that we will keep it.

+5 years seniority, senior executive, Lily

(2) *Alpha*. Our interviewees mentioned three separate entities after the acquisition: Alpha-Owner, Alpha-Prod and Sino-Beta (see Figure 1, presented in the methodology section). Yet, they frequently blurred the distinction between them and referred to all of these entities as "Alpha" or "Chinese". We describe the identity construction addressing managers' different forms of identification with these entities.

2.1 Alpha-Owner. Western managers were making sense of the new organizational ownership by comparing Alpha-Owner with the previous owner, Gamma. Interviewees mentioned that Alpha-Owner was a small organization led by a powerful leader, and financially supported by municipal governments. In contrast, Gamma was viewed as a large corporation which had profited from Beta-West's exceptional know-how. Interviewees were *ambivalent in their identification with the new owner (Alpha-Owner) and disidentified with*

the previous owner (Gamma). They lamented their lost autonomy under Gamma, which was seen as being responsible for Beta's financial problems before the Alpha acquisition. Having been on the brink of bankruptcy, Beta-West managers were happy with Alpha-Owner; they had survived and avoided bankruptcy, they were granted autonomy and received access to the resources needed to improve the business. This sentiment is reflected in the following statement:

Directions are set by Alpha-Owner but how to do things has been very much up to Beta-West. So a big change is that our Chinese have always referred to Beta-West in Europe as the head office. That had never happened before [the acquisition].

+15 years seniority, senior manager, Jim

On the negative side, Beta-West interviewees were suspicious that the new Beta factories in China would have an overcapacity. They also feared that all manufacturing would be moved to China, limiting Beta-West to R&D activities in the future once the Chinese had learned the business. The following testimonies illustrate shared concerns experienced:

I thought Alpha-Owner was quite a small company in China so I was wondering what they could contribute to us, because if they were just going to utilize technology and components from Beta-West. We didn't really know what was coming.

+15 years seniority, middle manager, Joy

Interestingly, addressing the ambivalent identification with their new owner, Beta-West managers were confused about the "owner identity" and unsure whether it was Alpha-Owner, Alpha-Prod or China. Indeed, they could not associate ownership with Alpha-Owner since it was viewed as small, irrelevant and without the necessary funds to have conducted the acquisition. For instance, one of the employees claimed that:

Yeah, so I didn't think about that much. But after a while we started to talk about the Alpha-[Owner] quite a lot. And then actually to be honest, most of the colleagues are not so happy about this acquisition. I can tell that. I mean I understand. I understand the feeling. In their world, Beta-West is really a great brand. And then we have very good products and then they have no idea about Alpha (here he means Alpha-Owner). And then to be honest, in my world, Alpha is like I don't know where they come from. I would never buy an Alpha (here the interviewee means Alpha-Prod) product in my life. Because I know they don't have good products. But then a small company just bought a bigger one. It's really – how to say?

+5 years seniority, junior manager, Susan

2.2 *Sino-Beta*. Sino-Beta counterparts were described as full of passion, eager to learn and fast moving. However, Beta-West managers showed an ambivalent identification with Sino-Beta. On the positive side, Beta-West managers appreciated their Chinese counterparts' ability to navigate the complex Chinese environment, negotiate with suppliers and obtain necessary information. This required personal relationships or friendships which were more difficult for Westerners to develop. For example, one employee claimed that:

So, relationship is very important, very important. If you don't have relationship you maybe have something else in the beginning to create a relationship.... I think you can say it feels pretty good because to be setting up the operation in China without any Chinese knowledge from Chinese people is very difficult.

+5 years seniority, senior executive, Simon

At the same time, the Chinese identity was often salient when Western managers mentioned Sino-Beta, and "China" was associated with a low quality, hazards, and lack of design. In this light, managers from Beta-West disidentified with the way Sino-Beta was doing business. Sino-Beta were viewed as excessively cost-driven, moving too fast and attaching too little importance to technical and quality issues. While cost-cutting gives short term results, quality problems surface in the long term, which Beta-West claimed their Sino-Beta counterparts would ignore. Beta-West employees were threatened by the Chinese way of doing business, which was believed could have a negative impact on Beta's identity and could destroy what Beta stood for as, for example, evident from the following quote:

Generally speaking, again, I would say many are, they are quicker. They want to get quickly through to the result. The result is more important than the way there. Sometimes it gets.... We need to get there. How we get there, the real content of that is, how sustainable that is for the future...sometimes it's more short-sighted.

+15 years seniority, senior executive, Lucy

2.3 *Alpha-Prod*. Managers in Beta-West described the low-quality products of Alpha-Prod as shameful. They preferred to remain separate from Alpha-Prod, and they had nothing to do with Alpha-Prod, which was described as a local Chinese company. Beta-West managers *disidentified* from Alpha-Prod. Western managers faced similar concerns regarding colleagues from Alpha-Prod as with Sino-Beta, fearing a potentially negative impact of

Alpha-Prod on Beta's reputation. European managers would have liked their company to be clearly separated from Alpha-Prod. For example, one of the interviewees claimed that:

In China, Alpha-Prod is a low-quality brand company. So, when people are talking about Alpha-Prod, then it means low quality. In this perspective, (Alpha-Prod) doesn't make me proud... I'm definitely not part of Alpha-Prod, because that is a completely different company and it's pure Chinese. People don't speak English. It's the Chinese management style. It's completely different with Beta-West.

+5 years seniority, senior manager, Sara

Collaboration

Overall, Western managers perceived collaboration with their Chinese counterparts as difficult. The latter were viewed as lacking in professional experience, and age differences between Beta-West and Chinese managers were stressed. Cultural differences were identified in communication and leadership. Many misunderstandings and different mind-sets thus emerged between the Sino-Beta and Beta-West teams. The following quote illustrates commonly shared challenges experienced by Western managers:

Our mindset is totally different. I've got the task to introduce Beta-West culture, processes and systems [to Sino-Beta], to hire people and train them to be able to work in a global environment based on Beta West development system and so on. (...) And I think my Chinese colleague [Sino-Beta] had a little bit a different target. Though we sat next to each other, we were never able to sit down together and to redefine the common goal or target. She was not a former Alpha manager, but she got the task to copy Alpha processes and systems and so on. And as I got the task to copy Beta-West, there was a fight every day more or less on how we should do it. So, we finally separated our responsibilities a little bit. So I could take care of the system, processes, culture and all that, and she could handle more the business side.

+15 years seniority, senior manager, David

Despite these challenges, Beta-West interviewees were willing to collaborate with Sino-Beta, since collaboration was viewed as necessary for Beta's successful business implementation in China. In fact, success in the large Chinese market was viewed as a key means to making Beta profitable again. Thus, despite differences, Beta-West managers wanted to share their know-how and build a strong Sino-West organization through an operational integration. Moreover, collaboration with Chinese counterparts was facilitated by their openness to learn, ambition and drive. One of the managers revealed:

I think for me it's more of a general China. I think you see that here also that they are very positive, very ambitious, they are quick. They are willing to learn. They are eager to learn; they are eager to develop. They know that they need to change.

+15 years seniority, senior manager, Andy

However, Western managers had less interest in collaborating with Alpha-Prod.

Separation from Alpha-Prod was viewed as necessary due to technology, brand and segment differences, as well as the fact that Alpha-Prod did not respect intellectual property (IP) standards, often violating IP by copying from competitors. The following quote illustrates the shared attitudes of Beta-West managers on collaboration with Alpha-Prod:

We need to understand that there is a clear boundary between the two companies (Beta-West and Alpha-Prod). We cannot share everything with them (Alpha-Prod). Therefore, we have created a lot of IT tools to prevent us from being hurt – I mean intellectual properties should also be considered between Alpha-Prod and Beta-West.

+15 years seniority, senior manager, Hopper

Time 2

Interventions to Integrate Sino-Beta and Beta-West

Between T1 and T2, collaboration between Sino-Beta and Beta-West managers intensified as a result of two major strategic initiatives. First, common production tasks between Beta-West and Sino-Beta were growing. They sourced the same components for the products and shared the production process with each other; this directly addressed quality concerns that were no longer an issue for Sino-Beta. Under the collaboration with Sino-Beta, global and Chinese sales of Beta products increased three-fold compared with T1. The first new product produced in China was sold on the global market, and the new products were announced to be produced in Chinese industries. Second, managers in both organizations had frequent and regular contact (by phone and video, but also face-to-face) and were getting to understand and be familiar with the other respective culture. For instance, Western managers travelled to China to visit Beta factories and take part in social activities with Chinese colleagues. Third, a “culture exchange program” was developed between Beta-West and Sino-Beta, through which Western managers went to Sino-Beta or Chinese managers went to Beta-West. In this way, good relationships with colleagues in Sino-Beta were built, and familiarity with the Chinese way of doing business was developed.

Interventions Separating Beta-West from Alpha-Prod

Separation of Beta-West from Alpha-Prod took place through AB-Tech, which was created by the Chairman in the same city as Beta-West. Though the latter was created around the time of the T1 interviews, only at T2 did it gain in relevance as experienced by Beta-West managers. AB-Tech was a development center for future Alpha-Prod and Beta products, and it operated as a Chinese organization characterized by high speed but the majority of the staff were European. The latter were highly-paid experts and were expected to bring knowledge to AB-Tech which was then supposed to be transferred to Alpha-Prod. Some Beta-West managers only collaborated with AB-Tech in global sourcing and R&D (but less with Alpha-Prod). AB-Tech successfully launched new, high-quality products for Alpha-Prod and Beta-West. Owing to the new organization, it was not necessary for Beta-West managers to collaborate directly with Alpha-Prod, which meant that their reputation would not suffer from the reputation of poor quality associated with Alpha-Prod.

Identity Integration

(1) *Common Beta*. Beta-West and Sino-Beta identities integrated into a Common Beta identity, which was viewed as a return to the “original”, “glorious” Beta, one that was independent and making decisions at the “original” Beta head office instead of being a subsidiary of a large multinational (Gamma). Beta-West managers considered Beta-West and Sino-Beta as the “Common Beta” identity, they were proud of “Common Beta” and they identified highly with their organization.

Thus, Beta was viewed as having become a truly global organization, going beyond its European heritage. Particularly, “independent” and “Western” were interchangeably evoked by all the interviewees, as evident in the following quote:

Beta works as a Western company with the ideas from the beginning [pre-Gamma era] ... The feeling of independence and feeling of “okay, even if we are Chinese-owned, we are still Beta. We are a Western company, Western brand and we can take care of our values. +10 years seniority, senior manager, Fern

“Common Beta” included Beta-West and Sino-Beta, and they were viewed as one organization with Chinese and Western employees working together from different geographical locations. Most importantly, the “Common Beta” identity was constructed alongside managers’ identification change, i.e., the ambivalent identification towards Sino-Beta (T1) changed into high identification with Sino-Beta (T2). Specifically, Beta-West managers no longer doubted the quality of products made in Sino-Beta, and Western managers stressed sharing both values and procedures with their Sino-Beta colleagues based

on the “best-of-both” principle, leading to a unique customer experience, as one of the managers explained:

In my area, we are like a team, it doesn't matter if he's sitting in China or wherever. We have meeting(s) every week.... we have daily contact with our colleagues in China.

+2 years seniority, senior manager, Gail

Interestingly, Beta-West managers also adapted to the “Sino-Beta way”, including a focus on higher speed and lower costs. For instance, they realized they could cut their costs through large volumes when purchasing together with Sino-Beta and Alpha-Prod. They emphasized that they had learned from Chinese colleagues about how to be faster, lower costs, and overall had become used to the Chinese way of doing business. They admitted that costs in Beta-West were sometimes too high and that it was a good opportunity to learn ways to cut costs from their Chinese colleagues:

It's just a bilateral communication process. If China says they have low prices, people from here will wonder why it is lower in China. They will try to do an analysis as to why it's lower, right? I need to learn from the others.

+2 years seniority, senior manager, Haley

Identity Separation

(2) *Alpha*. At T1, the identities of three separate entities were blurred: Alpha-Owner, Alpha-Prod, and Sino-Beta were all considered as “The Chinese” (see Fig. 1). Due to separation and integration interventions of the relevant organizations, Beta-West managers changed their forms of identification towards different entities. Specifically, at T2, these different organizational identities became clearer: “Beta-West” and “Sino-Beta” identities were integrated into “Common Beta”, the difference between Alpha-Prod and Alpha-Owner became clear and the new, and the AB-Tech identity became salient for Western managers (see Fig. 2).

2.1 Alpha-Owner. It was evident that Beta-West managers perceived Alpha-Owner as a “far-away supporter”. Alpha-Owner was viewed as playing a key role in granting Beta-West independence and allowing it to become a freestanding organization again. It was considered to stand behind Beta-West’s success, as illustrated in the following testimony:

I would say it's positive because we are expanding and it's giving us the opportunity to have a footprint in Asia in China, and with the funding we also started up the plant in the

US. We have the other Asian base, we have India, we have—it's really—so there I've seen probably we wouldn't be able to do all of that without our Owner.

+5 years seniority, middle manager, Jane

Beta-West managers showed a strong identification with “Alpha-Owner” which was perceived to be far away. However, Alpha-Owner provided large financial and network (government) support to Beta-West, enabling its rapid and successful internationalization in China. Moreover, comparisons of “The Owner” with the previous owner were reported by some interviewees, who noted an overall change for the better (T1: evidence of “The Owner” liberating Beta-West) as evident in the following statement:

As you said, it's been quite successful. Before it actually became an acquisition, it was, I think, most of people were worried and had a mindset of what's going to happen... That's what I think everyone thought before that. Then, it (acquisition) happened and I think within Beta-West we quite soon adapted to that situation. Okay, now it's a fact we are a part of a Chinese company.... Then all these investments took place and we started often and the more we got into this being Chinese owned, we realized: "okay, work is pretty much the same and we are very much independent.

+10 years seniority, senior manager, Kali

Interestingly, a majority of the interviewees reported an *increased identification* with a “Chinese” identity of Alpha-Owner. For example, Beta-West managers were not embarrassed about being owned by a Chinese company and they did not like their owner or China to be criticized in the local press or by friends and family. They emphasized that China is a large country with many contrasts, but overall China had reached a stage of development which allowed the production of high-quality products. In general, Beta-West employees were very positive about Alpha-Owner, for example:

But so far, so good, I would say. I'm not embarrassed that we're owned by a Chinese company at all. I think it's the result of the ownership that is the most important. I think many from the outside would think that now Beta is making cheap products, low quality products or something like that, so this is the worst from Chinese influence somehow that you can read if you read the comments on the news or blogs and things like that. Those who want to be mean they write that. They don't see the full picture and they don't know what's going on really because this cooperation is quite unique.

+15 years seniority, senior manager, Karan

2.2 *Alpha-Prod*. Interestingly, the previous *disidentification with Alpha-Prod* changed into a *neutral identification* for the interviewees. Particularly, Beta-West managers preferred not to talk about Alpha-Prod; they mentioned that they had nothing to say about it, or that Beta-West was a distinct organization from Alpha-Prod. This is particularly interesting as at T1, Beta-West interviewees disidentified with Alpha-Prod despite being structurally and linguistically separated and not really knowing their Chinese counterparts at Alpha-Prod. At T2, however, statements of “not knowing”/ “having nothing to say” when asked by the interviewer about Alpha-Prod, mean that Beta-West gave little thought to this organization and thus demonstrated a neutral identification towards Alpha-Prod, as illustrated by the following quote:

Alpha-Prod is doing what they are doing and we are doing what we are doing. But still, we are under the same umbrella [Alpha-Owner]. I don't think there are many in the company that actually know a lot about Alpha-Prod. We know they make [insert the product's name], we also make [insert the product's name], but it's not the same [insert the product's name] anyway.

+10 years seniority, senior manager, Eda

2.3 *AB-Tech*. A new AB-Tech identity became salient at T2. AB-Tech was recognized as a joint venture because, despite being owned by Alpha-Owner, it was based in the same city as Beta-West and recruited many specialists from Beta-West and other Western companies who were attracted by higher salaries. Western managers were *ambivalent in their identification* with AB-Tech. On the positive side, from the perspective of Western managers, it was a good idea to create the new organization, since AB-Tech would take responsibility for R&D collaboration between Alpha-Prod and Beta-West. It meant that their reputation would not be hurt by Alpha-Prod. The new organization was developing fast and it had grown from a team of dozens of people to over one thousand in three years. A new, high quality product was successfully launched by AB-Tech. AB-Tech is perceived as taking the “best of both”, as one of the employees claimed:

AB-Tech took the best part of the Alpha-Prod way on the work because that was completely different, and the best part of Beta-West and then created a new process. That has basically been the standard now.

+15 years seniority, senior manager, Jim

On the negative side, Western managers viewed AB-Tech as a young operation that required to put in place processes. AB-Tech was viewed as too flexible and insufficiently systematic. Few Beta-West interviewees showed an interest in working in AB-Tech. One of the interviewees claimed that:

I don't know if I should say embarrassing but this chaotic situation, I know some of the people from Beta-West that started there [AB-Tech], they quit and moved back to Beta-West because they couldn't stand it. It was too... no clear decisions, everything changing all the time, no documentation.

+15 years seniority, senior manager, Rea

Collaboration

Strong commitment to collaborate with Sino-Beta was evident among Beta-West managers. Chinese colleagues were described as well-educated, English-speaking and welcoming. Western managers claimed that over the past years they had become familiar with their Chinese colleagues from Sino-Beta and both sides had adapted to each other. Specifically, a shared rhythm of work was established across their teams, and they became used to cultural differences with regard to communication and leadership structure. The majority of Western and Chinese managers who worked in Sino-Western teams not only regularly maintained contact with each other through email and telephone, they also participated in the exchange program that lasted several weeks. For example, one of the interviewees claimed of the exchange program:

We have a good thing in our department where we can go on a cultural exchange program where we stay abroad in China for nine weeks and the Chinese come and stay for about the same time and just exchange cultural vigor. And my experience from that was really good and many people in our department went on this program and I think it's a very good thing. You understand more and get to know each other. And one thing is, everyone who went to China realized they are very welcoming.

+10 years seniority, senior manager, Tanya

Furthermore, more willingness to collaborate with Sino-Beta on the common project was salient, which resulted in shared successes in terms of production in China, higher sales and profitability. These successes were viewed impossible to achieve without the Sino-West collaboration. For example, one of the Western managers claimed that:

Yes, we have a group here and we have colleagues in China and we have meetings every week, we have meetings, the commodity meetings and review for the projects since we

have common tasks in global... global tasks that we drew together. We have to always align the products we are preparing for Europe and also for China, so to align or know the complete strategy.

+2 years seniority, senior manager, Macy

In contrast, there was less interest of Beta-West managers in collaborating with Alpha-Prod counterparts. Such a collaboration was viewed as unnecessary due to different market segments, but also as potentially difficult due to language barriers. European managers greatly appreciated that they were not obliged to cooperate with Alpha-Prod, which had in fact been viewed as a threat at T1. Indeed, at T2 it became clear for European managers that Alpha-Prod was a separate and different organization. Instead, our interviewees stressed it was easier to collaborate with AB-Tech than with Alpha-Prod. AB-Tech was an Alpha-Prod R&D center, based in the same city as Beta-West, but which recruited many European specialists, including some from Beta-West. Thus, collaboration with AB-Tech counterparts was viewed as easier than with Alpha-Prod. AB-Tech was welcomed as a boundary spanning organization between Beta and Alpha-Prod, as for example expressed in the following quote:

They [Alpha-Prod] also have a company here [AB-Tech], as you know, doing R&D for both Alpha-Prod and Beta-West. And that cooperation works quite well...I think we have had quite clear boundaries but we collaborate intensively between Beta-West and AB-Tech. Because many of employees working there [AB-Tech], originally come from here [Beta-West]. So, there are many relationships established between employees, and basically I think there's quite a trustful relationship between us.

+15 years seniority, senior executive, Sunny

Discussion

Our in-depth case study provides insights into the construction of multiple identities in cross-border M&As by answering the initial questions: i) how do members of a European organization construct their multiple identities over time after being acquired by a Chinese organization? and ii) what are the key factors in the changing dynamics of multiple organizational identities? In this section, we will provide response to those two research questions.

Construction of Multiple Identities after the Acquisition

At T1, five identities were salient with negative and positive forms of identification triggering high ambivalence towards the acquisition (see Figure 3). Two of these identity targets positively contributed to the overall evaluation of the acquisition: increased identification with

Beta-West, and disidentification from Gamma, the previous owner. First, disidentification from Gamma positively contributed to the overall evaluation of the acquisition. Prior to the acquisition by Alpha, Beta-West experienced humiliation under its previous owner, and our interviewees experienced nostalgia for the glorious past when Beta had been a standalone company. Indeed, as a result of the acquisition by Gamma, Beta identity continuity was disrupted and thus, Beta managers disidentified from Gamma, which is in line with research of (Fiol et al., 2009; Haslam et al., 2003) who demonstrate a negative impact of a low identity continuity on the post-merger identification. This brings us to the first key contribution of our paper, namely the importance of historical identities to facilitate change in M&As and the harmonious co-existence of multiple identities. Whereas pre-merger identity refers to the attributes of the organization upon entering the current acquisition (van Leeuwen et al., 2003), historical identity refers to the attributes of the organization as viewed to exist upon the firm's inception (Hatch and Schultz 2017). The removal of a negative bond from the pre-merger identity (i.e. disidentification from Gamma, previous owner of Beta), together with a reinforced identification with the historical identity (Beta) contributed positively to the overall evaluation of the acquisition. In other words, Beta interviewees considered the acquisition by the Alpha-Owner as a return to their past glory, which had been disrupted by Gamma. This echoes findings of a qualitative, longitudinal study on the use of historical artefacts in identity building conducted by Hatch and Schultz (2017). They found that maintaining historical heritage can positively shape employees' experiences of organizational change. Our results of the role of historical identities in M&As complement insights from a qualitative case study conducted by Joseph (2014). He found that the preservation of a pre-merger identification improves employees' overall willingness to change their organizational identification. Moreover, maintaining historical identities might be particularly relevant in Sino-Western acquisitions because Western societies tend to negatively evaluate Chinese acquirers (Riad et al., 2012). In this context, keeping the historical identity of a Western acquired firm would improve employees' identification with the Chinese owner.

Key Factors in Changing Dynamics of Multiple Organizational Identities

The evaluation of the acquisition was highly ambivalent at T1, with both positive and negative forms of identification co-existing. At T2, we observed a change in ambivalence as the problematic forms of identification became positive forms of identification (see Figure 4). While multiple identities were opposed as experienced by Beta-West members at T1, at T2

simultaneous identification with multiple foci was possible. We provide understanding into under-investigated change in ambivalence towards an acquisition (Chreim and Tafaghod, 2012) and multiple identities (Sarala et al., 2019) by elaborating the expanded model of identification (Kreiner and Ashforth, 2004). This brings us to the second key contribution, namely the importance of a boundary spanning, ambivalent identity (AB-Tech identification) which helped separate the positive (Beta-West) from the negative (Alpha-Prod) identities prevalent at T1. Consequently, interviewees acknowledged that Alpha-Prod was a separate (structurally and cognitively) organization in which Beta-West employees would no longer be in contact with Alpha-Prod, and the latter was viewed as no longer part of the acquisition. The emergence of this ambivalent identification facilitated a focus on a positive orientation (Beta), while paying less attention to the negative one (Alpha-Prod). Creating an ambivalent boundary spanner identity suggests a novel approach into change processes, which relies on dialectical thinking on the part of the acquirer, which is generally widespread in East Asian cultures (Spencer-Rodgers et al., 2004). Our findings provide empirical evidence of Asian firms' tendency to pursue simultaneously two seemingly tensional objectives by creating intermediate objects as AB-Tech (Chen and Miller, 2011). While the interviewees described AB-Tech to be an "Alpha-Beta joint-venture", it was an Alpha-Prod organization in the hometown of Beta-West, created with an objective to decrease interdependence between Beta-West and Alpha-Prod.

Between T1 and T2 task and human integration interventions (Birkinshaw et al., 2000) of Beta-West and Sino-Beta took place e.g. culture adaptation program, multiple face-to-face exchanges and virtual team collaboration between European and Chinese managers. In terms of the task integration, successes of Beta were possible only because of the Sino-Beta and Beta-West human integration, and included the following: manufacturing sites in China; remarkable increase in global sales of Beta-West; and new products produced and launched by Sino-Beta with Beta-West for global markets. Such response relates to what Amiot et al. (2007) call "additive integration" (p. 377), which is regarded as the most positive identity development. In this context, at T2 interviewees changed into a high identification with Alpha-Owner as well as with both Beta-West and Sino-Beta (ambivalent identification at T1), which together synergized into "Common Beta", i.e., both European and Chinese organizations were viewed as one "Beta" organization. This might not have been possible without decoupling of conflicting identities (Alpha-Prod from Beta) which may not only

decrease an intergroup conflict (Fiol et al., 2009), but also enable more positive views on the previously negative or ambivalent identities.

In summary, the reduction of ambivalence results from concurrent integration and separation interventions: ambivalent boundary spanning identity separates positive from negative identities, and integration can foster the development of a new, shared post-merger identity, based on a “best-of-both” or “self-other integration” principle (Chen and Miller, 2011).

Practical Implications for Sino-Western M&As

We believe that our study makes several contributions for practitioners on Chinese acquisitions in developed economies. We confirm that the negative reactions of Western managers towards their Chinese acquirers might be present at the early stages of M&As, but positive evaluations of the acquisition can emerge with effective managerial interventions. Indeed, in the case of acquisitions by Chinese firms, problems in M&As may not be created by cultural distance per se, but rather by the process of how the socio-cultural integration is managed (Stahl and Tung, 2015). Our data suggests that, in order not to pose a threat for Western managers, providing them with autonomy might not be sufficient, as it might prevent Chinese acquirers from meeting their acquisition goal and gaining synergies. Creating an ambivalent boundary-spanning identity might allow to concurrently separate positive from negative identities and to integrate those identities, which are necessary for reaching task synergies for both acquired, and acquiring organizations. These interventions can be replicated in all contexts where a Chinese company aims at acquiring a Western company with sophisticated technology and innovation.

Limitations and Implications for Future Research

The findings presented in our paper are based on an in-depth case study of a Chinese acquisition of a European company. Relying on a qualitative methodology, our study allows an analytical rather than a statistical generalization. In the future, scholars may be interested in conducting a mixed method (qualitative and quantitative) investigation building on a multiple embedded case study design to gain a better understanding of multiple identity construction processes as experienced by different stakeholders in various entities involved in the acquisition. For example, in our paper, there are two organizations in Europe (Beta-West and AB-Tech), two organizations in China (Sino-Beta and Alpha-Prod), and their members

might experience multiple identity construction differently. This approach could shed light on context-sensitive insights in the construction of multiple identities.

Conclusion

In our paper, we consider the complexity related to multiple identities in cross-border M&As, together with the different forms that these identities might take, in the context of Chinese acquisitions. This is an under investigated phenomena from a process perspective (Deng, 2013), and to which the extant literature on M&As might not apply. The findings reveal that organizational identity change is facilitated by aligning of a post-merger identity with the acquired organizations' historical identity and by installing of an ambivalent boundary spanning identity. Consequently, the reduction of ambivalence over time results from concurrent integration and separation interventions: ambivalent boundary spanning identity separates positive identities from negative ones, and integration foster the development of a new, shared identity.

References

- Amiot, C.E., De la Sablonnière, R., Terry, D.J., and Smith, J.R. (2007), “Integration of social identities in the self: toward a cognitive-developmental model”. *Personality and Social Psychology Review*, Vol. 11 No. 4, pp. 364–388.
- Ashforth, B.E. and Johnson, S.A. (2001), “Which hat to wear? The relative salience of multiple identities in organizational contexts.”, in Hogg, M.A. and Terry, D.J. (Eds.), *Social Identity Processes in Organizational Contexts*, pp. 32–48.
- Ashforth, B. E., and Mael, F. A. (1996). “Organizational identity and strategy as a context for the individual.” *Advances in Strategic Management*, Vol. 13, No.13, pp.19–64.
- Ashforth, B.E., Rogers, K.M., Pratt, M.G., and Pradies, C. (2014), “Ambivalence in organizations: a multilevel approach”, *Organization Science*, Vol. 25 No. 5, pp. 1453–1478.
- Ashforth, B. E., Schinoff, B. S., and Rogers, K. M. (2016), “I identify with her,” “I identify with him”: unpacking the dynamics of personal identification in organizations. *Academy of Management Review*, Vol. 41 No. 1, pp. 28–60.
- Birkinshaw, J., Bresman, H., and Håkanson, L. (2000), “Managing the post-acquisition integration process: how the human integration and task integration processes interact to foster value creation.” *Journal of Management Studies*, Vol. 37 No. 3, pp. 395–425.
- Chen, M.J. and Miller, D. (2011), “The Relational Perspective as a Business Mindset: Managerial Implications for East and West.”, *Academy of Management Perspectives*, Vol. 25 No. 3, pp. 6–18.
- Cheng, J. L. C. (2014), “Country context in management research: learning from John Child: country context in management research.” *Management and Organization Review*, Vol. 10 No. 3, pp. 337–346.
- China M&As market review in 2016 and outlook in 2017: pp.1–38. PwC Report. Available from URL: <https://www.pwccn.com/en/services/deals-m-and-a/publications/ma-2016-review-and-2017-outlook.html>
- Chreim, S. and Tafaghod, M. (2012), “Contradiction and sensemaking in acquisition integration”, *The Journal of Applied Behavioral Science*, Vol. 48 No. 1, pp. 5–32.
- Clark, S.M., Gioia, D.A., Ketchen, D.J. and Thomas, J.B. (2010), “Transitional Identity as a Facilitator of Organizational Identity Change during a Merger”, *Administrative Science Quarterly*, Vol. 55 No. 3, pp. 397–438.

- Corbin, J., and Strauss, A. (2008), “Basics of qualitative research: techniques and procedures for developing grounded theory”, Thousand Oaks, CA: Sage.
- Corley, K.G., and Gioia, D.A. (2004), “Identity ambiguity and change in the wake of a corporate spin-off”, *Administrative Science Quarterly*, Vol. 49 No. 2, pp. 173–208.
- De Bernardis, L. and Giustiniano, L. (2015), “Evolution of multiple organisational identities after an M&A event: A case study from Europe”, *Journal of Organizational Change Management*, Vol. 28 No. 3, pp. 333–355.
- Deng, P. (2013), “Chinese outward direct investment research: theoretical integration and recommendations”, *Management and Organization Review*, Vol. 9 No. 3, pp. 513–539.
- Fiol, C.M., Pratt, M.G., and O’Connor, E.J. (2009), “Managing intractable identity conflicts”, *Academy of Management Review*, Vol. 34 No. 1, pp. 32–55.
- Giessner, S.R., Ullrich, J. and van Dick, R. (2011), “Social identity and corporate mergers”, *Social and Personality Psychology Compass*, Vol. 5 No. 6, pp. 333–345.
- Gioia, D.A., Patvardhan, S.D., Hamilton, A.L. and Corley, K.G. (2013), “Organizational Identity Formation and Change”, *The Academy of Management Annals*, Vol. 7 No. 1, pp. 123–193.
- Glaser, B.G., and Strauss, A.L. (1967), *The discovery of grounded theory: Strategies for qualitative research*. Aldine, New York.
- Haslam, S.A., Postmes, T., and Ellemers, N. (2003), “More than a metaphor: organizational identity makes organizational life possible.” *British Journal of Management*, Vol. 14 No. 4, pp. 357–369.
- Hatch, M.J. and Schultz, M. (2017), “Toward a theory of using history authentically: historicizing in the Carlsberg group”, *Administrative Science Quarterly*, Vol. 62 No. 4, pp. 657–697.
- Irwin, J., Lahneman, B. and Parmigiani, A. (2018), “Nested identities as cognitive drivers of strategy”, *Strategic Management Journal*, Vol. 39 No. 2, pp. 269–294.
- Joseph, J. (2014), “Managing change after the merger: the value of pre-merger ingroup identities”, *Journal of Organizational Change Management*, Vol. 27 No. 3, pp. 430–448.
- Klossek, A., Linke, B.M. and Nippa, M. (2012), “Chinese enterprises in Germany: establishment modes and strategies to mitigate the liability of foreignness”, *Journal of World Business*, Vol. 47 No. 1, pp. 35–44.

- Kreiner, G.E. and Ashforth, B.E. (2004), "Evidence toward an expanded model of organizational identification", *Journal of Organizational Behavior*, Vol. 25 No. 1, pp. 1–27.
- Langley, A. (1999), "Strategies for theorizing from process data", *The Academy of Management Review*, Vol. 24 No. 4, pp. 691–710.
- Li, J., and Wan, G. (2016), "China's cross-border mergers and acquisitions: a contextual distance perspective." *Management and Organization Review*, Vol. 12 No. 3, pp. 449–456.
- Lupina-Wegener, A., Schneider, S.C., and van Dick, R. (2015), "The role of outgroups in constructing a shared identity: A longitudinal study of a subsidiary merger in Mexico." *Management International Review*, Vol. 55 No. 5, pp. 677–705.
- Miles, M.B., Huberman, A.M., Huberman, M.A. and Huberman, M. (1994), *Qualitative Data Analysis: An Expanded Sourcebook*, sage.
- Pettigrew, A.M. (1990), "Longitudinal field research on change: theory and practice", *Organization Science*, Vol. 1 No. 3, pp. 267–292.
- Piderit, S.K. (2000), "Rethinking resistance and recognizing ambivalence: A multidimensional view of attitudes toward an organizational change", *Academy of Management Review*, Vol. 25 No. 4, pp. 783–794.
- Popper, K. (2005), *The Logic of Scientific Discovery*, Routledge.
- Pratt, M.G., and Rafaeli, A. (1997), "Organizational dress as a symbol of multilayered social identities", *Academy of Management Journal*, Vol. 40 No. 4, pp. 862–898.
- Riad, S., Vaara, E. and Zhang, N. (2012), "The intertextual production of international relations in mergers and acquisitions", *Organization Studies*, Vol. 33 No. 1, pp. 121–148.
- Rui, H., and Yip, G.S. (2008), "Foreign acquisitions by Chinese firms: a strategic intent perspective", *Journal of World Business*, Vol. 43 No. 2, pp. 213–226.
- Sarala, R.M., Vaara, E. and Junni, P. (2019), "Beyond merger syndrome and cultural differences: New avenues for research on the 'human side' of global mergers and acquisitions (M&As)", *Journal of World Business*, Vol. 54 No. 4, pp. 307–321.
- Spencer-Rodgers, J., Peng, K., Wang, L., and Hou, Y. (2004) "Dialectical self-esteem and east-west differences in psychological well-being." *Personality and Social Psychology Bulletin*, Vol. 30 No.11, pp. 1416–1432.

- Stahl, G.K., and Tung, R.L. (2015), "Towards a more balanced treatment of culture in international business studies: the need for positive cross-cultural scholarship", *Journal of International Business Studies*, Vol. 46 No. 4, pp. 391–414.
- Suri, H. (2011), "Purposeful sampling in qualitative research synthesis." *Qualitative Research Journal*, Vol. 11 No. 2, pp. 63–75.
- Tajfel, H., and Turner, J. C. (1986), *The social identity theory of intergroup behavior*. In S. Worchel & WG Austin (Eds.), *Psychology of intergroup relations: 7-24*. Chicago: Nelson-Hall.
- Turner, J.C. (1985), "Social categorization and the self-concept: a social cognitive theory of group behavior", *Advances in Group Processes*, Vol. 2, pp. 77–122.
- Turner, J.C., Hogg, M.A., Oakes, P.J., Reicher, S.D., and Wetherell, M.S. (1987), *Rediscovering the Social Group: A Self-Categorization Theory.*, Basil Blackwell.
- Vaara, E., Tienari, J., and Säntti, R. (2003), "The international match: metaphors as vehicles of social identity-building in cross-border mergers", *Human Relations*, Vol. 56 No. 4, pp. 419–451.
- Van Dick, R., Christ, O., Stellmacher, J., Wagner, U., Ahlswede, O., Grubba, C., Hauptmeier, M., et al. (2004), "Should I stay or should I go? Explaining turnover intentions with organizational identification and job satisfaction.", *British Journal of Management*, Vol. 15 No. 4, pp. 351–360.
- Van Leeuwen, E., Van Knippenberg, D. and Ellemers, N. (2003), "Continuing and changing group identities: The effects of merging on social identification and ingroup bias", *Personality and Social Psychology Bulletin*, Vol. 29 No. 6, pp. 679–690.
- Wei, T. and Clegg, J. (2018), "Effect of organizational identity change on integration approaches in acquisitions: Role of organizational dominance: effect of organizational identity change", *British Journal of Management*, Vol. 29 No. 2, pp. 337–355.
- Weick, K.E. (1995), *Sensemaking in Organizations*, Sage Publications, Thousand Oaks.
- Yildiz, H.E., and Fey, C.F. (2016), "Are the extent and effect of psychic distance perceptions symmetrical in cross-border M&As? Evidence from a two-country study", *Journal of International Business Studies*, Vol. 47 No. 7, pp. 830–857.
- Yin, R.K. (2009). *Case Study Research, Design & Methods* 4th ed.
- Yin, R.K. (2017), *Case Study Research and Applications: Design and Methods*, Sage publications.
- Zheng, N., Wei, Y., Zhang, Y. and Yang, J. (2016), "In search of strategic assets through cross-border merger and acquisitions: evidence from Chinese multinational

enterprises in developed economies”, *International Business Review*, Vol. 25 No. 1, pp. 177–186.

Table 1. Chronological description of the key events

Month 1	Alpha-Owner bid for Beta-West and sought full ownership.
Month 5-8	Negotiations between Gamma and Alpha-Owner with a definitive agreement signed in month 5.
Month 15	Alpha opened Sino-Beta as a subsidiary of Beta-West in China. Sino-Beta employees reported to Sino-Beta and Beta-West managers.
Month 21	“Manager Match” project began. Every expatriate from Beta-West in China had a match at Sino-Beta, i.e., a manager in the same job and position as an expatriate.
Month 31	AB-Tech was built - a new R&D Center of Alpha-Prod to foster new R&D developments between Alpha-Prod and Beta.
Month 40	Beta was decentralized. Beta-West employees reported only to Beta-West managers and Sino-Beta employees reported only to Sino-Beta managers.
Month 41	Three production sites of Beta launched in China.
Month 37 – Month 41	T1 data collection.
Month 76	Common production tasks between Beta-West and Sino-Beta were growing. There was a remarkable increase in Beta-West global sales.
Month 77 – T2	“Culture exchange program” was reinforced between Beta-West and Sino-Beta employees. European managers spent 3 months at Sino-Beta and Chinese spent 3 months at Beta-West.
Month 78 – T2	AB-Tech grew fast and focused on the development of a new, flagship machine for Alpha-Prod. Mainly work of European engineers and designers (also recruited from Beta-West), with support from Alpha-Prod expatriates.
Month 79	Some Beta-West managers only collaborated with AB-Tech in global sourcing and in R&D (but less with Alpha-Prod). New product positively viewed by the industry experts and media, successfully launched in China and to be sold on global markets in the new future.
Month 80	The first new product produced and launched in global market by Sino-Beta and Beta-West.
Month 81	New products were announced to be produced wholly in Chinese industries of Sino-Beta.

Month 76 – Month 81	T2 data collection.
------------------------	---------------------

Table 2: Overview of the interviewee

	Number	Position	Seniority
T1	16 interviews	2 executives 9 senior managers 3 middle managers 1 junior manager	9 interviewees: over 15 years (at Beta before acquisition by Gamma) 5 interviewees: 6-14 years (at Beta under ownership by Gamma) 1 interviewee: “new comer” 0-5 years (at Beta under ownership by Alpha)
T2	20 interviews, including 4 with the same individuals interviewed at T1	1 executive 12 senior managers 3 middle managers 4 junior managers	6 interviewees: over 15 years (at Beta before acquisition by Gamma) 8 interviewees: 6-14 years (at Beta under ownership by Gamma) 6 interviewees: 0-5 years (at Beta under ownership by Alpha)

Table 3. Multiple identities, change in ambivalence and the code frequency¹

Time 1 (High ambivalence towards the acquisition)	Time 2 (Low ambivalence towards the acquisition)	
Multiple opposite identities	Identity integration	Identity separation
<p><i>Disidentification with Gamma (12/15)</i></p> <p>“Gamma was draining us of money and know-how. So, we were like a squeezed lemon by the time Alpha-owner took us over. Now we got to gain possibilities to do what we are strong at, to do again what we did before. That’s an interesting thing.”</p>		<p><i>Ambivalent identification with AB-Tech (new identity) (16/20)</i></p> <p>Positive: “Creating AB-Tech would make the collaboration between Beta-West and Alpha-Prod possible”</p> <p>Negative: “The speed and the flexibility that was there in the beginning was lost after a while because it grew too fast.”</p>
<p><i>Identification with Beta-West (14/15)</i></p> <p>“I think actually we are very proud of our Beta-West. We are very proud of our people, products and brand”</p>		
<p><i>Ambivalent Identification with Sino-Beta (15/15)</i></p> <p>Positive: “They want to learn from somebody else’s mistakes, which is very clever.”</p> <p>Negative: “They want to get over troubles at a quicker speed. But sometimes is not good to be quick.”</p>	<p><i>Identification with “Common Beta” (Sino-Beta and Beta-West) (16/20)</i></p> <p>“Sino-Beta is the same company as Beta-West, but different location, different region.”</p>	

¹ Numbers in the parenthesis correspond to the frequency of the codes i.e. illustrate the number of interviewees who mentioned the codes over the total number of interviewees. We found circa 75% agreement among interviewees on each code.

<p><i>Ambivalent identification with Alpha-Owner (13/15)</i></p> <p>Positive: saved and financed by new owner comparing with bad situation under Gamma</p> <p>Negative: “We have no idea about Alpha and to be honest, Alpha is like ... (here he means Alpha-Owner). I don’t know where they come from. I would never buy an Alpha (here he means Alpha-Prod) product in my life.”</p>		<p><i>Identification with Alpha-Owner (15/20)</i></p> <p>“I think it (Alpha-Owner) has been mostly positive and now that we also built more plants for production in China”</p>
<p><i>Disidentification with Alpha Prod (14/15)</i></p> <p>Negative: “Unfortunately, they have poor brand reputation, poor quality”.</p>		<p><i>Neutral Identification with Alpha-Prod (15/20)</i></p> <p>“It doesn’t really bother me, I think, as long as they leave Beta-West alone.”</p>

Figure 1. Interorganizational collaboration at T1

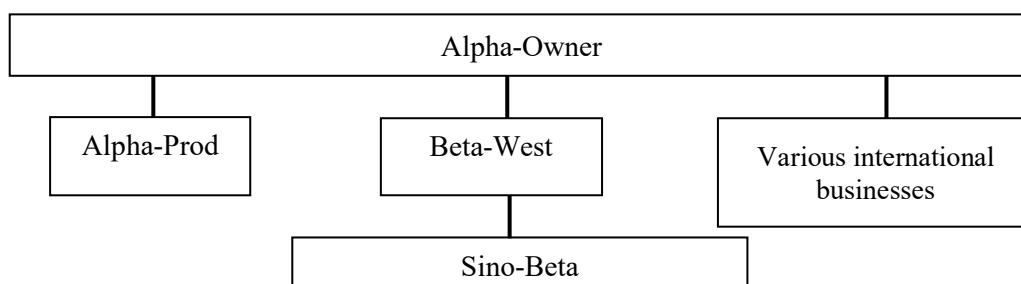

Figure 2. Interorganizational collaboration at T2

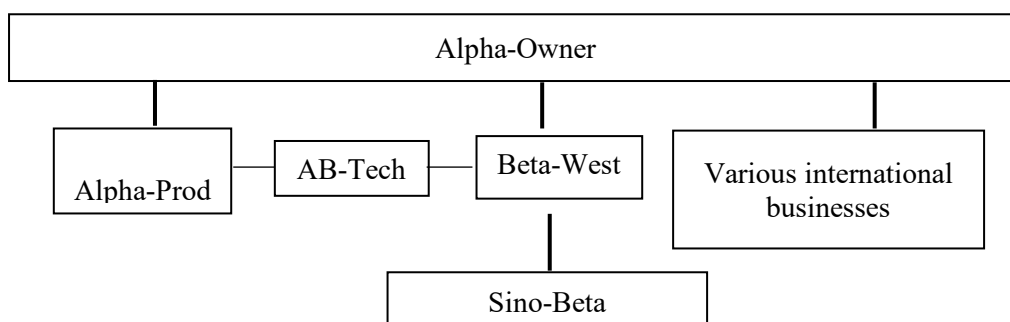

Figure 3. Multiple forms of identification in the Alpha-Beta acquisition at T1

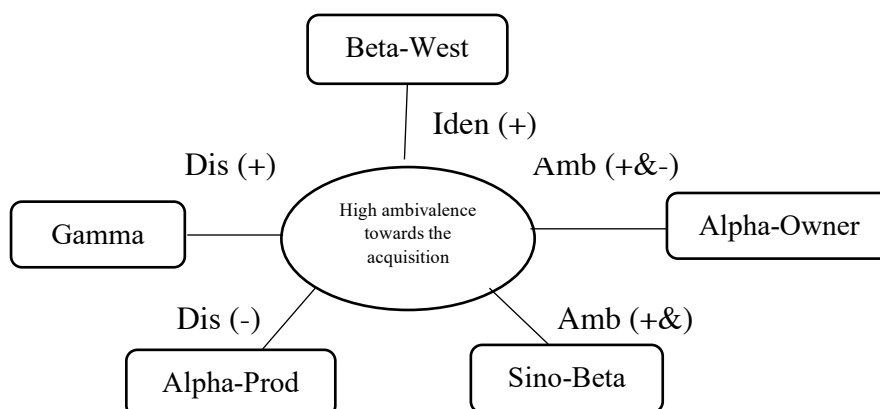

Figure 4. Multiple forms of identification in the Alpha-Beta acquisition at T2

