

Integration of the Road Slope in the Optimization of the Energy Management Strategy of a parallel HEV

A. Pam^{1,2,3}, A. Bouscayrol^{1,3}, P. Fiani², F. Faval², P. Barrade⁴

¹Univ. Lille, Arts et Métiers ParisTech, Centrale Lille, HEI, EA 2697 - L2EP, F-59000 Lille, France

²Sherpa Engineering, 92250 La Garenne-Colombes, France

³MEGEVH, French network on HEVs, l2ep.univ-lille1.fr/megevh, France

⁴Institute of Systems Engineering, School of Engineering, HES-SO Valais-Wallis,
Route du Rawil 47, CP 2134, 1950 Sion 2, Switzerland

Corresponding author: Alain Bouscayrol

E-mail: Alain.Bouscayrol@univ-lille.fr

Abstract: Optimization methods for Energy Management Strategy (EMS) are more and more used to minimize the fuel consumption of Hybrid Electric Vehicles (HEV). For off-line techniques, such as dynamic programming, from a given driving cycle, an algorithm is defined to determine the optimal power flows of the vehicle. Most of the time, the optimization is achieved by not considering the resistive force due to the road slope, which can be very high in certain roads depending on the mass of the vehicle. This paper aims to quantify the accurate fuel consumption economy when the road slope is integrated or not in the EMS optimization problem of a parallel HEV using dynamic programming.

© 2019, IFAC (International Federation of Automatic Control) Hosting by Elsevier Ltd. All rights reserved.

Keywords: Road slope, Optimization, Energy Management Strategy, Hybrid Electric Vehicle

I. INTRODUCTION

The world mobility continues struggling with some economic and environmental threats (IEA, 2015). Electric vehicles are certainly a promising solution for mobility improvement. Unfortunately, the low autonomy and the long charging time of their batteries are major constraints. Hybrid electric vehicles (HEV) are more and more used to avoid those constraints (Chan et al., 2010).

In the development phase of HEVs, simulation is an important step. Indeed, control schemes and Energy Management Strategies (EMS) are developed and validated using physical models (Guzzella et al., 2013). According to the objective of the simulation or the study, assumptions are made in the modelling to allow fast testing (Gao et al., 2007) (Chan et al., 2010) (Aziz et al., 2011) (Denis et al., 2018). For the EMS development of HEV, the resistive force due to road slope is rarely considered. However, it might lead to some error on the fuel consumption estimation, especially if the vehicle mass is important. Indeed, the force due to the road slope, called also gradient force, depends on the slope, the mass of the vehicle and the gravity (Ehsani et al., 2004). Then, if the road slope is important, the required traction power can be large. In fact, most of the time, the road slope is neglected because of the lack of parameters on the used driving cycles. For example, standard driving cycles such as NEDC or WLTC do not consider any slope. Techniques have even been developed to determine the road slope (Bae et al., 2001) (Hellstrom et al., 2007) (Mangan et al., 2007) (Sebsadji et al., 2008) (Sahlholm

et al., 2010). This estimation is mainly used to determine the gradeability of the vehicle in function of the vehicle mass and the gearbox ratio (Yamsani, 2014).

This paper aims to quantify the effective fuel consumption of a plug-in parallel HEV when the resistive force due to the road slope is considered or not. In that aims, dynamic programming (DP) is used to solve the optimization problem of the EMS of the vehicle. For the EMS optimization, a backward approach is used for the vehicle model. A forward model of the vehicle, organized by the Energetic Macroscopic Representation (EMR) (Bouscayrol et al., 2000) (Bouscayrol et al., 2012) will help in validating the optimal EMS.

Section II presents the organization of the complete forward model and control scheme of the studied vehicle thanks to EMR. In Section III, the road slope is not considered for the identification of an optimal EMS. In Section IV, an optimized EMS considering the road slope is achieved using dynamic programming and validated on the forward model.

II. GLOBAL MODELLING AND CONTROL OF THE STUDIED VEHICLE

A. EMR of the studied Vehicle

The studied vehicle is a plug-in parallel hybrid powertrain composed of an ICE of 43 kW and an electric drive of 20 kW with a li-ion battery (Figure 1). The vehicle weight is 1.3 t.

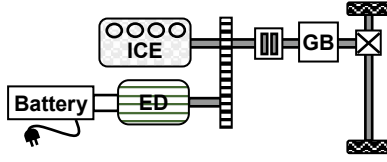

Figure 1: plug-in parallel HEV structure

Battery – The battery is considered as voltage source, V_{bat} , composed of an open circuit voltage, V_{oc} , in series with an internal resistance, R_{bat} , in function of the battery State-of-Charge (SoC) and the current, i_{bat} (Johnson, 2002).

$$v_{bat} = V_{co}(SoC) - R_{bat}(SoC)i_{bat} \quad (1)$$

Electric drive – The electric drive is composed of a voltage source inverter and an induction machine. A dynamic model could be developed. But, in a macroscopic study for EMS identification, a comparison between the dynamic model of the electric drive and a static model based on its efficiency map shows less than 1% error in the energy consumption (Letrouvé et al., 2010). By using the efficiency map for the electric drive, the torque of the induction machine is then determined (2).

$$\begin{cases} T_{em} = T_{em_ref} \\ i_{bat} = \frac{T_{em}\Omega_{em}}{\eta_{em}^k v_{bat}} \end{cases} \quad \text{with: } k = -sign(T_{em}\Omega_{em}) \quad (2)$$

Internal combustion engine (ICE) – The ICE is considered as a mechanical controlled torque source. A static model (iso-consumption map), which delivers the ICE torque, T_{ice} , in function of a reference torque, T_{ice_ref} , is developed.

$$T_{ice} = T_{ice_ref} \quad (3)$$

Mechanical transmission – The mechanical transmission is composed of a belt-pulley coupling, a clutch, a gearbox with five gear ratios, a differential, the wheels, and the chassis of the vehicle. The belt-pulley output torque, T_{blt} , is obtained by the sum of the torques of both the induction machine and the ICE, in function of the ratio, k_{blt} , and the efficiency, η_{blt} . The ICE speed is the same as the input speed of the clutch, Ω_{clu} .

$$\begin{cases} T_{blt} = \eta_{blt}^k (k_{blt}T_{em} + T_{ice}) \\ \Omega_{em} = k_{blt}\Omega_{clu} \end{cases} \quad (4)$$

$$\text{where } k = \begin{cases} 1 & \text{for } P_{blt} \geq 0 \\ -1 & \text{for } P_{blt} < 0 \end{cases}$$

The complex structure of the clutch makes its model too difficult to achieve. Moreover, when comparing a study with clutch to a study without clutch, the energy impact is very low (1%) due to its short time use (Letrouvé et al., 2009). An ideal clutch is thus considered in this study. Considering that the vehicle moves on a straight line, an equivalent wheel is used for the model. So, the clutch, the gearbox, the differential and the wheels, can be considered as one mechanical power converter which converts a rotational movement to a linear movement. The wheel force, F_{wh} , is obtained with the belt-pulley torque and the equivalent ratio and efficiency of the mechanical power converter, k_{mt} and η_{mt} . The same logic is used for the speeds, to determine the speed in the machines side of the clutch, Ω_{clu} , with the vehicle velocity, v_{veh} .

$$\begin{cases} F_{wh} = \eta_{mt}^k k_{mt} T_{blt} \\ \Omega_{clu} = k_{mt} v_{veh} \end{cases} \quad \text{where: } \begin{cases} k_{mt} = \frac{k_{clu}k_{gb}k_{dif}}{r_{wh}} \\ \eta_{mt} = \eta_{gb}\eta_{dif} \end{cases} \quad (5)$$

The chassis of the vehicle determines the vehicle motion by its mass. So, the vehicle velocity, v_{veh} , is determined by using the dynamic relationship of a mass in translating movement.

$$M_{veh} \frac{dv_{veh}}{dt} = F_{wh} - F_{res} \quad (6)$$

Road – The road of the vehicle characterizes the equivalent resistive force, F_{res} , to the vehicle motion. The equivalent resistive force is composed of the rolling force, F_{rol} , the aerodynamic force, F_{aero} , and the force due to the road slope, F_{stop} . The latter depends on the mass of the vehicle, the gravity, g , and the slope (8).

$$F_{res} = F_{aero} + F_{rol} + F_{stop} \quad (7)$$

$$\text{where: } F_{stop} = M_{veh}g(\sin \alpha) \quad \text{with } \alpha, \text{ the road slope} \quad (8)$$

EMR is a graphical formalism used to organize models of complex systems. Energy sources are depicted by green pictograms, energy storages by crossed orange rectangles, energy converters by orange squares or circles and energy distribution elements by overlapped squares (see appendix). The complete EMR of the vehicle is presented by Figure 2 (Pam et al., 2017).

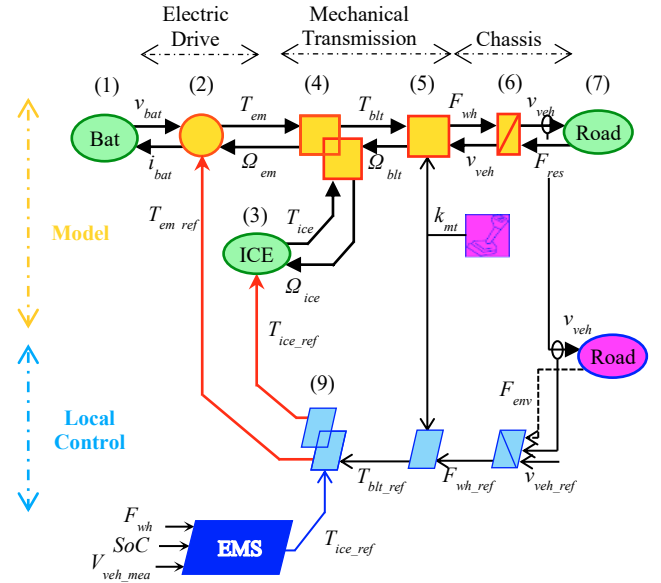

Figure 2: EMR and control of the plug-in parallel HEV

B. Control Organization of the Vehicle

The aims of the control of the vehicle is to deliver the right tuning input to the system in order to achieve a given objective, which is the vehicle velocity. The inversion of the EMR leads to the control scheme. To build the control scheme, each relationship type in the model is inverted. According to EMR rules, if the relationship in the model has no delay, the inversion is directly achieved. But, if the relationship yields a delay, then, a closed-loop control is needed in the inversion. By the inversion of the EMR, the control scheme of the plug-

in parallel HEV is deduced (Figure 2). Estimations are made for non-measurable variables like F_{res} .

For the EMS study, this paper is focused on the power flow distribution between the electric drive and the ICE (9). So, it is assumed that the braking is fully electric. The EMS delivers the requested torque of the ICE.

$$T_{em_ref} = \frac{1}{k_{blt}} (T_{blt_ref} - T_{ice_ref}) \quad (9)$$

III. OPTIMAL EMS OF THE VEHICLE NEGLECTING THE ROAD SLOPE

A. Backward Model for Dynamic Programming

Dynamic programming (DP) is widely used to determine the optimum behaviour of a system (Guzzella et al., 2010). However, future events must be known in advance in order to determine the optimum. This makes the dynamic programming unusable in real time, in the context of parallel HEV where future constraints applied to the vehicle by the environment are difficult to be predicted. Nevertheless, it allows to obtain a theoretical optimum. So, its result can be a benchmark for other real-time usable methods.

The principle developed in this contribution is then to identify an optimal behaviour of the parallel HEV using a backward modelling approach where future events can be taken into account. In the second step, the optimized EMS is tested on forward-based model such as that one presented in Figure 2 for tests and pre-validation of results in a real-time configuration. Then, in order to use DP for determining an optimized EMS, a “backward” model is required. EMR can be easily converted into a backward model (Mayet et al, 2014). This “backward” model is based on equation (10). It is a model simplification as the control is now considered ideal. The total traction force is calculated based on the velocity of the vehicle, the acceleration, the resistive force. The “backward” model of the plug-in parallel HEV can be deduced from EMR (Figure 3).

$$F_{veh} = M_{veh} \frac{dv_{veh}}{dt} + F_{env} \quad (10)$$

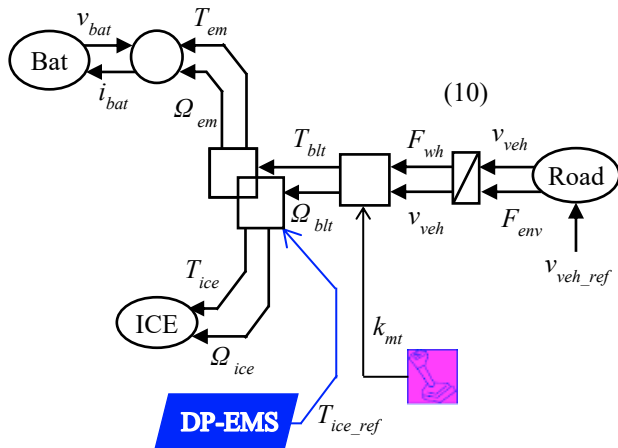

Figure 3: Backward EMR-based model of the parallel HEV

Optimization by dynamic programming is based on the principle of optimality of Bellman (Bellman, 2003). The principle is to divide the problem in locally optimized sub-problems which will lead to an overall optimization of the system.

B. Optimal EMS neglecting the road slope

The goal is there to minimize the ICE fuel consumption. The minimal consumption is the sum of the minimal consumptions between two operating points of the ICE. The cost function is defined as the fuel consumption. The equation that solves the optimization problem of this cost function is given (11). To solve this matter for minimizing the cost function, constraints are set on the SoC of the battery and the distribution coefficient (12). The cost function and the defined constraints allow to calculate the optimal SoC of the battery that gives the minimal cost for each point of the driving cycle. The ideal evolution of the SoC is then calculated to achieve the minimum of the fuel consumption. Based on this approach, the optimized EMS using DP is determined (Figure 4). It defines the optimal requested torque of the ICE.

$$J^* = \min(J) = \sum_{i=0}^{N-1} L(\text{SoC}(i), T_{ice_ref}(i)) \cdot \Delta \quad (11)$$

where: J , the cost function is the fuel Consumption. L is the lowest cost function between two samples (fuel flow). i , is the actual point on the driving cycle, and, Δ as an illustration.

$$\begin{cases} \text{SoC}_{min} \leq \text{SoC}(i) \leq \text{SoC}_{max} \\ \text{SoC}(i_{end}) = \text{SoC}(i_{start}) \\ \widetilde{T}_{ice} \leq T_{ice_ref}(i) \leq \widehat{T}_{ice} \end{cases} \quad (12)$$

The road slope is a parameter that is difficult to determine. Generally, most of the time it is not considered for the EMS optimization. This EMS is determined neglecting the road slope.

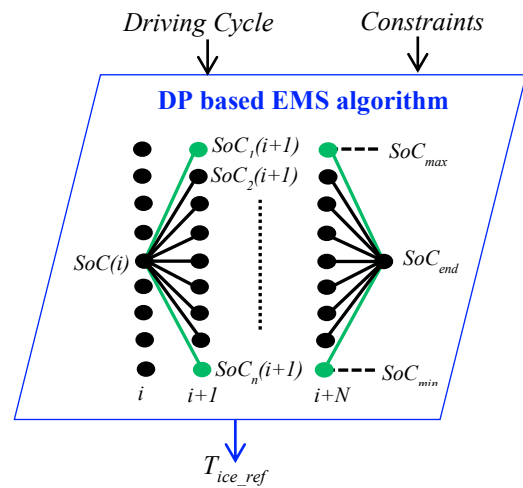

Figure 4: DP-EMS calculation (no road slope)

Some simulations have been made through a real driving cycle covering a distance of 188 km in “Canton de Vaud / Switzerland” from Lausanne and back (Figure 5).

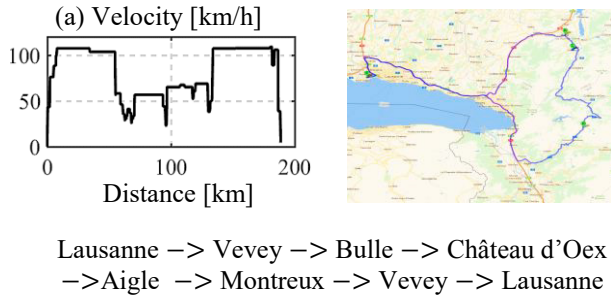

Figure 5: Travelling map in "Canton de Vaud / Switzerland"

The results of the DP-EMS with the backward model gives a fuel consumption around the 3.99L/ 100 km (Figure 6). The constraints on the battery SoC are well respected.

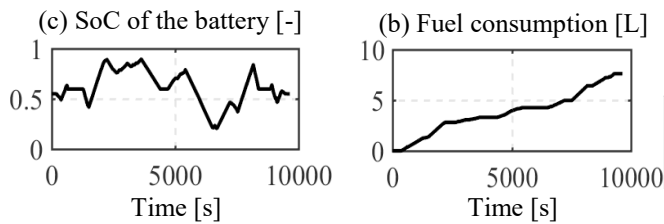

Figure 6: Results of DP-EMS without road slope

C. Validation on the vehicle forward model

The DP-EMS determined without road slope is applied to the forward model considering the road slope for the evaluation of the real performances of the obtained DP-EMS in a more realistic simulation approach. Comparative results are presented in Figure 7.

The fuel consumption is increased up to 9% when the DP-EMS is applied to the forward model (with road slope) compared to the backward model. In fact, because the road slope is considered in the forward model, the traction power increases in some parts of the cycle, and the optimality, which was defined by the DP without the road slope, cannot be respected anymore. The consequence is that the ICE does not operate in its optimal areas. The fuel consumption is thus higher than expected.

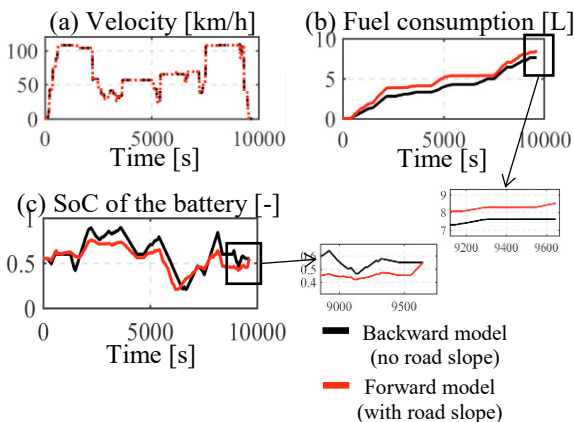

Figure 7: Results for DP-EMS (no road slope)

The physical limitations on the system has a big effect on the fuel consumption (Figure 8). In fact, a zoom in the torques of the ICE and the induction machine shows that, in some areas, in the backward model (without road slope), the ICE was used to charge the battery while powering the vehicle. But, in the forward model (with road slope), because of the increase of the traction power, the ICE is requested to deliver more power. Even, in some areas, the power delivered by the ICE is not sufficient to power the vehicle at that speed, because of its physical limitations. The battery is then used to supply the rest of the traction power. This causes the increase of the fuel consumption and the depletion of the SoC of the battery.

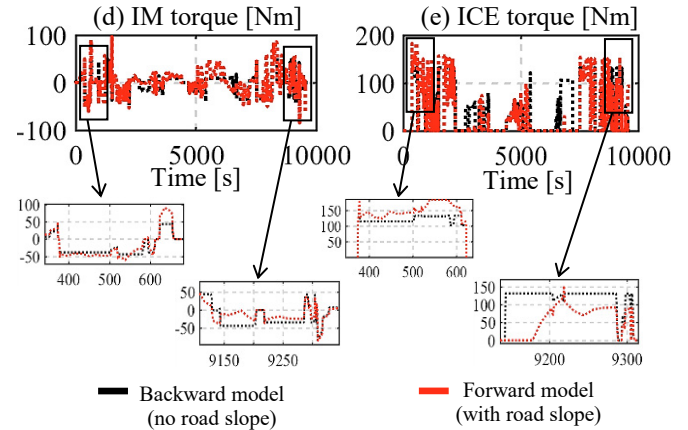

Figure 8: Analysis of the physical limitations

IV. OPTIMAL EMS OF THE VEHICLE INTEGRATING THE ROAD SLOPE

A. Optimal EMS integrating the Road Slope

In this section, the road slope is considered for the EMS development. Based on the same approach, the optimized EMS using DP with the road slope is determined (Figure 9). It determines the requested torque of the ICE.

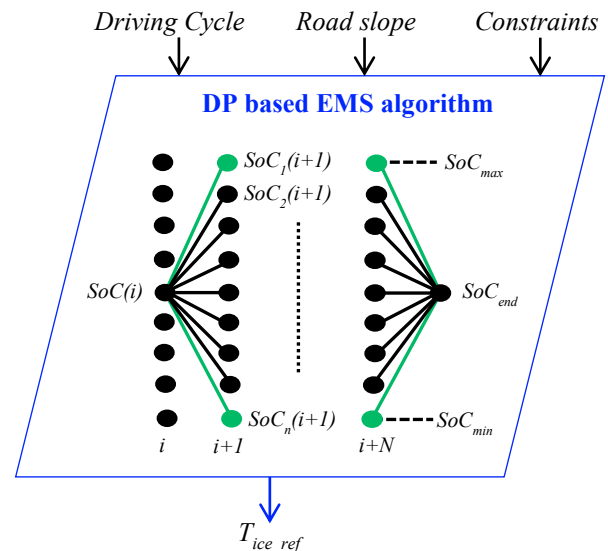

Figure 9: DP-EMS calculation (with road slope)

B. Validation on the Vehicle Forward Model

The simulations are made through the same real-life driving cycle (Figure 5). But in this case the road slope is considered. The velocity of the vehicle, the elevation, the road slope and the evolution of F_{stop} , in function of the distance are presented by Figure 10.

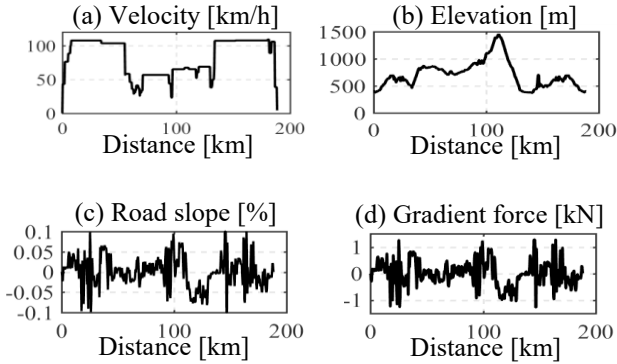

Figure 10: Real-life Driving cycle in “Switzerland”

The DP-EMS with road slope is run with the forward model and compared to the results with the backward model (Figure 11).

The reference velocity is well achieved. In terms of fuel consumption, overall, the difference is less than 1%. It is related to the difference between the forward modelling approach and the backward. In fact, in the backward modelling approach, the control is assumed ideal. But in the forward model, a closed-loop control is developed to assure the tracking of the reference vehicle velocity. However, the constraints on the SoC of the battery are respected. That indicates that the model reduction with the backward organization does not lead to an important error.

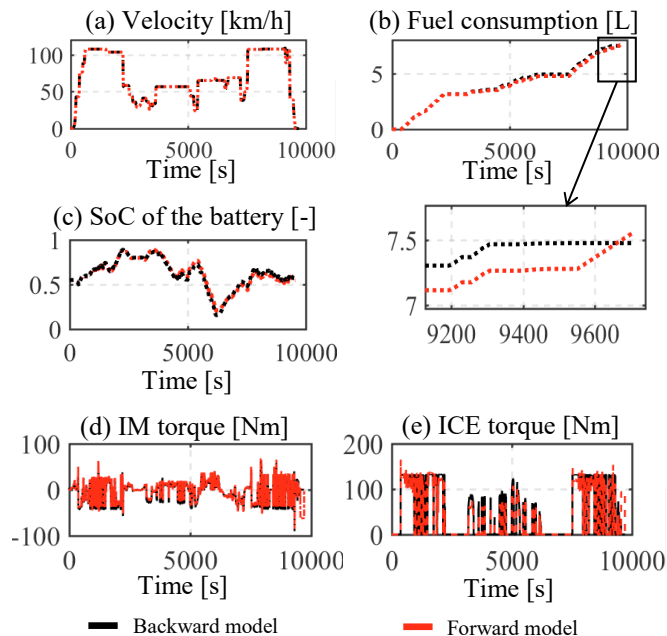

Figure 11: Results for DP-EMS (with road slope)

C. Discussion on the Interest of considering the Road Slope in the EMS optimization

The effect of the road slope is quite obvious on the fuel consumption (TABLE I). Furthermore, when neglected in the optimization of the EMS, if the defined EMS is applied on the model with road slope, the fuel consumption increases up to 9%. That percentage represents the error that is made in the model by not considering the road slope. In fact, when the road slope is considered in the optimization of the EMS, there is no error on the model.

It is better then, to consider the road slope in the optimization problem in order to keep the optimality of the system.

TABLE I. Fuel consumption comparison

	DP-EMS (no road slope)	DP-EMS (with road slope)
Backward model	3,99 L / 100 km	4,01 L / 100 km
Forward model	4,35 L / 100 km	4,03 L / 100 km
Error	9 %	0,4 %

V. CONCLUSION

Two different models of a plug-in parallel HEV has been studied for the optimization of the EMS. They are based on consideration or not of the road slope of a real-life driving cycle. Dynamic programming has been used for the optimization of the EMS with two backward models considering or not the road slope. Each EMS algorithm has been applied to the forward model considering the road slope as in the real case. There is no error on the model when the road slope is considered in the EMS optimization. But the error is 9% when the road slope is not considered in the EMS optimization. Furthermore, when the road slope is considered, the EMS can assure of the optimality of the system. So, in the case of high gradients for important mass vehicles, it is better to considered the road slope for the EMS studies and optimization in order to avoid unreliable results.

ACKNOWLEDGMENT

This paper was written in the goal of a PhD thesis. The authors would like to gratefully thank the ANRT (French agency of technologic research) for its financial support and the French network on HEVs: MEGEVH.

REFERENCES

- A. Aziz, M. S. Shafqat, M. A. Qureshi, I. Ahmad, 2011. “Performance Analysis of Power Split Hybrid Electric Vehicles using Autonomie”. IEEE – Stud. Conf. on Research and Development, December 2011.
- A. Bouscayrol, B. Davat, B. de Fornel, B. François, J. P. Hautier, F. Meibody-Tabar, M. Pietrzak-David, 2000. “Multimachine Multiconverter System: application for electromechanical drives”, European Physics Journal - Applied Physics, vol. 10, no. 2, pp. 131-147, May 2000.

A. Bouscayrol, J. Paul Hautier, B. Lemaire-Semail, 2012. “Graphic Formalism for the Control of Energetic Multiphysics Systems”. Systemic Design for Electrical Energy Conversion, Volume 1, Management, Analysis and Synthesis, Chapter 3, Hermes Editions, ISBN: 978-2-7462-3192-4, November 2012.

A. Yamsani, 2014. “Gradeability for Automobiles”. IOSR Journal of Mechanical and Civil Engineering, Vol. 11, Issue 2, Ver. VII, April 2014, pp. 35-41.

C. C. Chan, A. Bouscayrol, K. Chen, 2010. “Electric, Hybrid and Fuel Cell Vehicles: Architectures and Modeling”, IEEE Trans. on Veh. Techn., vol. 59, no. 2, pp. 589-598, February 2010.

C. Mayet, L. Horrein, A. Bouscayrol, P. Delarue, J. N. Verhille, E. Chatot, B. Lemaire-Semail, 2014. “Comparison of different models and simulation approaches for the energetic study of a subway”, IEEE Trans. on Veh. Techn., Vol. 63, no. 2, February 2014, pp. 556-565.

D. W. Gao, C. Mi, A. Emadi, 2007. “Modeling and Simulation of Electric and Hybrid Vehicles”. Proc. IEEE, vol. 95, no. 4, pp. 729-745, April 2007.

E. Hellström, M. Ivarsson, J. äslund, L. Nielsen. "Look-ahead Control for Heavy Trucks to Minimize Trip Time and Fuel Consumption", IFAC Proceedings Volumes, Volume 40, Issue 10, 2007, Pages 439-446.

H. S. Bae, J. Ryu, J. C. Gerdes, 2001. “Road Grad and Vehicle Parameter Estimation for Longitudinal Control using GPS”. IEEE – ITS’01, Oakland (CA), USA, August 2001.

International Energy Agency, 2015. “Statistics database”, website of IEA, <http://www.iea.org/media/statistics>, 2015.

L. Guzzella, A. Sciarretta, 2010. “Vehicle propulsion systems, introduction to modelling and optimization”. Second Edition, Springer, ISBN 978-3642094156, October 2010.

L. Guzzella, A. Sciarretta., 2013. “Supervisory Control Algorithms”. Vehicle Propulsion Systems, Springer Berlin Heidelberg, pp. 243-276, 2013.

M. Ehsani, Y. Gao, S. E. Gay, A. Emadi, 2004. “Modern Electric, Hybrid Electric, and Fuel Cell Vehicles”. Elec. Eng., CRC Press, March 2004.

N. Denis, M.R. Dubois, J.P.F. Trovão, A. Desrochers, “Power Split Strategy Optimization of a Plug-in Parallel Hybrid Electric Vehicle”, IEEE trans. on Vehicular Technology, vol. 67, no. 1, January 2018, pp. 315 - 326.

P. Sahlholm, K. H. Johansson, 2010. “Road Grade Estimation for Look-ahead Vehicle Control using Multiple Measurement Runs”. Science Direct, Control Engineering Practice, Vol. 18, October 2010, pp. 1328-1341.

R. Bellman, 2003. “Dynamic Programming”, Princeton University Press 1957, Dover Publication ISBN 0-486-42809-5, Mineola, New York, Reprint 2003.

S. Mangan, J. Wang, 2007. “Development of a Novel Sensorless Longitudinal Road Gradient Estimation Method Based on Vehicle CAN Bus Data”. IEEE/AMSE Trans. on Mechatron., Vol. 12, no. 03, January 2007, pp. 375-386.

T. Letrouve, A. Bouscayrol, W. Lhomme, 2009. “Influence of the clutch model in a simulation of a parallel Hybrid Electric Vehicle”. IEEE – VPPC’09, Dearborn (Michigan, USA), September 2009.

T. Letrouve, A. Bouscayrol, W. Lhomme, N. Dollinger, F. M. Calvairac, 2010. “Different Models of a Traction Drive for An Electric Vehicle in Simulation”. IEEE – VPPC’10, Lille (France), September 2010.

V. H. Johnson, 2002. “Battery Performance models in ADVISOR”. J. Power Sources, vol. 100, No. 2, pp. 321-329, August 2002.

Y. Sebsadji, S. Glaser, S. Mammam, 2008. “Road Slope and Vehicle Dynamics Estimation”. American Control Conference, Seattle (WA), USA, June 2008.

NOMENCLATURE: VARIABLES ACRONYMS

v - Electric voltage [V]	T - Angular torque [Nm]
i - Electric current [A]	v - Linear velocity [Km/h]
R - Electric resistance [Ω]	F - Linear force [N]
SoC - State-of-Charge [-]	M - Mass [Kg]
Ω - Rotational speed [rpm]	k - Ratio coefficient [-]
α - Road slope [%]	η - Efficiency [-]

APPENDIX: EMR PICTOGRAMS

	Action and reaction variables $P = e_1 e_2$		Energy source
	Accumulation element (energy storage)		Indirect inversion (closed-loop control)
	Mono-domain conversion element		Direct inversion (open-loop control)
	Mono-domain coupling element (energy distribution)		Coupling inversion (energy criteria)
	Power adaption		Energy Management Strategy