

Piezoelectric-based monitoring of pressure variations in inkjet printhead

Bullot Loïc, Chabert Ull Carlos, Filliger Sebastian, Brügger Luca

iPrint, Route de l'Ancienne Papeterie 180, 1723 Marly Switzerland
HEIA-FR, HES-SO University of Applied Sciences and Arts Western Switzerland

Abstract

The popularity of inkjet technology is growing in the industry due to the many benefits it brings. However, the complexity of the process and hardware required to deliver a drop on demand accurately and at high speed poses a reliability challenge. With many complex parameters in the ink and printhead affecting drop quality, maintaining a stable environment is key.

There has been increasing interest in sensing technologies that use the piezoelectric actuator in the nozzle to measure the acoustic response of the nozzle chamber. Several papers have been published on the use of piezo sensing to detect nozzle status.

The aim of this paper is to present an innovative way of measuring the ink pressure within the nozzle chamber by sensing the piezoelectric response. Driving and measurement are performed using custom hardware to quantify the acoustic response of the system after actuation of the piezo. The variations in the dominant frequency of the response signal can then be correlated with variations in pressure.

This method makes it possible to measure pressure variations along the print head, opening up a range of new possibilities for identifying events that can have a direct impact on print quality.

Introduction

Drop-on-demand (DoD) inkjet printheads are a key element in many industries and are gradually replacing more traditional technologies such as screen printing[1], gravure, offset printing, etc. Inkjet brings huge benefits to many industrial processes, but also new challenges. In particular, the print quality and robustness of inkjet processes are strongly influenced by the ink pressure at the printhead[2]. This can be explained by the relationship between the printhead pressure and the meniscus pressure, and ultimately the speed and shape of the jetted drop. It is therefore necessary to emphasise the importance of pressure in inkjet printing.

DoD piezo-based printheads use the piezo actuator to generate pressure waves in the nozzle chamber that create a drop and eject it from the nozzle[3]. These piezo actuators are excited by the application of a waveform signal, causing them to deform. The residual waves due to the movement of the ink in the nozzle chamber can be sensed using the direct sensing effect of the piezo-actuator[4].

The aim of this research is to explore the capabilities of the built-in piezoelectric element used to jet drops to measure pressure variations. This technique is an important step in characterising the hydraulic behaviour in printheads. The method presented provides a better understanding of the internal state of the printhead. This technique allows on-line testing during production processes, is time efficient and suitable for industrial use, and is a cost effective solution as it uses the built-in piezo actua-

tors for sensing without the need for external sensors.

Theoretical basis

The motivation behind the experiences discussed in this paper is that piezo sensing can measure the frequency of the pressure waves generated when a drop is ejected. This frequency correlates with the static pressure in the printhead and would allow the latter to be measured.

The aim of this chapter is not to give theoretically exact results, but to understand the tendency and whether there is a correlation between the static pressure and the frequency of the pressure waves. To this end, several physical mechanisms are simplified or even neglected if they are invariant to pressure changes.

The print head is simplified to a single degree of freedom system consisting of the nozzle chamber and the nozzle, as shown in Figure 1[5]. The single degree of freedom is the fluid displacement in the nozzle. When the fluid enters the nozzle from the chamber, the pressure in the chamber decreases and opposes the fluid motion and vice versa. This means that an actuation of the piezo, forcing ink out of the chamber will then create and oscillation back and forth of ink in and out of the nozzle chamber.

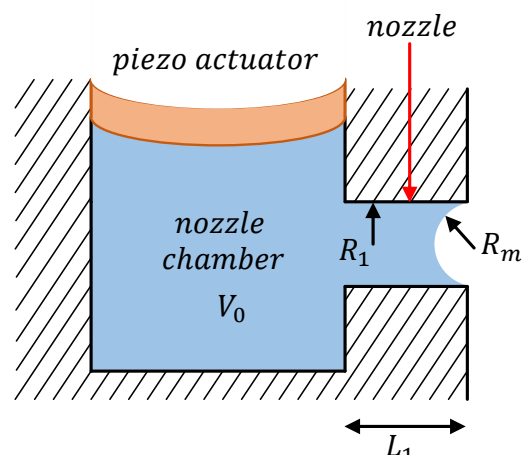

Figure 1. Single degree of freedom schematic of one nozzle from a piezo-driven printhead. R_1 : radius of the nozzle, V_0 : Volume of fluid in the chamber, R_m : bending radius of the meniscus, L_1 : length of the fluid column in the nozzle

The behaviour of the system is similar to that of a mechanical spring as shown in the figure 2. The fluid in the nozzle oscillates against the compressibility of the fluid in the nozzle chamber, damped over time by viscous dissipation [5].

When the printhead is not jetting, the meniscus is stationary, and its shape and position are determined by the pressure difference between the ink and the ambient condition. Typically, the ink is set to a slight negative pressure to prevent leakage and the

meniscus is curved inwards.

Ignoring the effect of damping on the frequency of oscillation, the Rayleigh method can be used to calculate the resonant frequency[5]. It states that in conservative undamped systems the action is governed by the exchange of potential and kinetic energy.

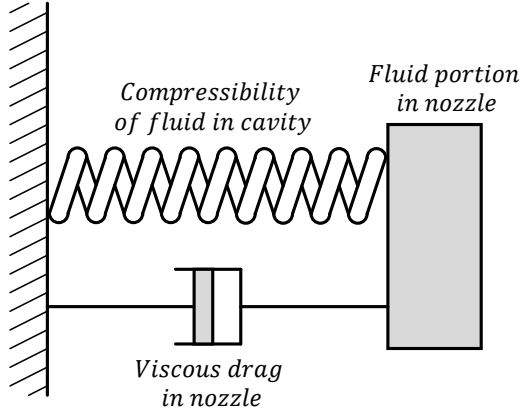

Figure 2. Mechanical analog of the nozzle

The kinetic and potential energies are given by the following equations:

$$T = \frac{1}{2}M\dot{x}_1^2 \quad \text{and} \quad U = \frac{1}{2}Cx_1^2 \quad (1)$$

Where:

- T : Kinetic energy
- U : Potential energy
- M : Mass of the mass-spring-damper system
- C : Stiffness of the mass-spring-damper system
- x_1 : Mean fluid displacement in the nozzle

The absence of dissipation means that the sum of potential and kinetic energy remains constant. During a harmonic oscillation, when the amplitude of the displacement is maximum, the kinetic energy is zero and the potential energy is maximum. Conversely, when the displacement is zero, the potential energy is zero and the kinetic energy is maximum. This leads to equality:

$$T_{max} = U_{max} \quad (2)$$

In harmonic motion, $x_1 = B\cos(\omega t)$ with ω being the natural angular frequency. The equality to becomes:

$$\frac{1}{2}MB^2\omega^2 = \frac{1}{2}CB^2 \quad (3)$$

$$\omega^2 = \frac{C}{M} \quad (4)$$

The natural frequency of the harmonic motion is given by:

$$f_n = \frac{\omega_n}{2\pi} = \frac{1}{2\pi} \sqrt{\frac{C}{M}} = \frac{c}{2\pi} \sqrt{\frac{1}{V_0} \frac{A_1}{L_1}} \quad (5)$$

Where:

- f_n : Natural frequency
- ω_n : Natural angular frequency
- c : Speed of sound in the fluid
- V_0 : Volume of fluid in the chamber
- A_1 : Surface area of the nozzle
- L_1 : Length of the column of fluid in the nozzle

In equation 5, c , A_0 and V_0 are constant and the only value that varies with ink pressure is L_1 . When the pressure difference is close to zero, the length of the fluid column would tend to be the length of the nozzle. As the static ink pressure becomes lower, the fluid column becomes shorter and the frequency should increase. The problems that arise when $L_1 \rightarrow 0$ are also ignored because the model only makes sense when the pressure conditions are good for jetting and the meniscus is not broken.

This result neglects several interactions in the fluid, but allows the assumption that the frequency is inversely proportional to the pressure:

$$f \propto \frac{1}{p} \quad (6)$$

Where:

- f : Frequency of the sensing response
- p : Pressure of the ink relatively to ambient pressure

Materials

The setup used during the research consisted of the different elements shown in Figure 3. In order to carry out the measurements for the experiment, it was necessary to be able to control the nozzles in the print head, the ink conditions and the pre-processing, and to measure the electrical response of the piezo actuator. A custom system was therefore developed to allow easy automation of the measurements to study the relationship between pressure and the self-sensing signal.

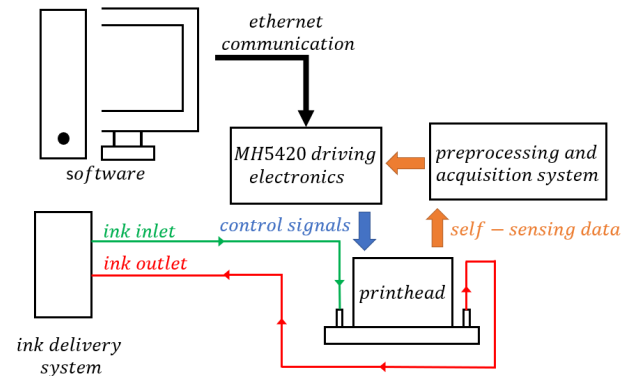

Figure 3. Block diagram of the measurement setup

In this study we used the MH5420 industrial inkjet printhead (manufactured by Ricoh, Japan), which has 1,280 nozzles configured in 4 x 150dpi rows[6]. This printhead was used because of the ability to measure the piezo response directly through the electronic drivers used to control the piezo actuators, and also because the geometry of the nozzle chamber simplifies the modelling of the equivalent mechanical analogue due to single-endedness, as shown in Figure 1.

The ink delivery system is a key element of the set-up, ensuring that ink pressure conditions are controlled by a dual pressure regulator. It is capable of selecting an inlet and outlet pressure and maintaining stability with a maximum deviation of 0.1 millibar. By controlling the recirculation flow and meniscus pressure through the printhead, the system ensures optimum ink delivery. Inlet and outlet pressures are relative to ambient pressure and technical abbreviations will be explained when first used.

Figure 4 illustrates the equivalent circuit used to drive and acquire the self-sensing signal. A trapezoidal pulse is generated by direct digital synthesis, producing a current draw which is passed through a shunt resistor and amplified by an isolated amplifier to achieve excellent common mode rejection at high frequencies, followed by a differential amplifier and a logarithmic amplifier to compress the dynamic range.

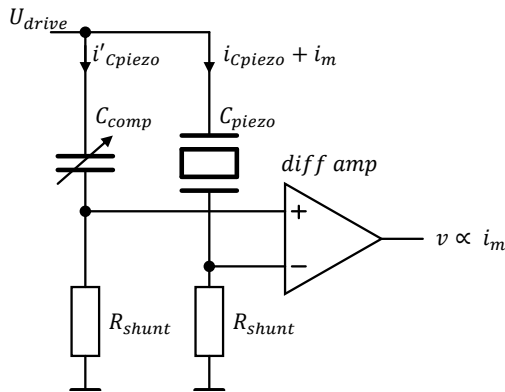

Figure 4. Signal processing and measurement circuit

Previous studies at iPrint and by others have shown that the current induced by the mechanical stress of the pressure wave can be 100 to 1000 times less than the piezo drive current[7]. For this reason, the measurement circuit is designed to compare the current from the actuated piezo with the current flowing through an inactive nozzle and a compensation capacitor. The latter is calibrated to be close to the capacitance of the piezo.

Methodology

The waveform used for these tests was a single pulse of duration equal to one acoustic period of the response, allowing maximum energy in the residual pressure waves after jetting. Immediately after actuation of the piezo, the measurement shows a damped sinusoid, which is the sensing response of the nozzle. The nozzles must be measured individually so that the piezo signals don't add up.

Figure 5 shows the sensing response at different static pressures. The frequency of the response signal is extracted through a fast Fourier transform(FFT). The full range of pressure that the nozzle allow create less than 1% of difference of frequency. Because of that the resolution of the FFT needs to be high enough, 62.94Hz in this experiment for frequencies over 100kHz.

Measurements were made by sweeping pressures from -5mBar to -25mBar and taking the median of the nozzle frequency

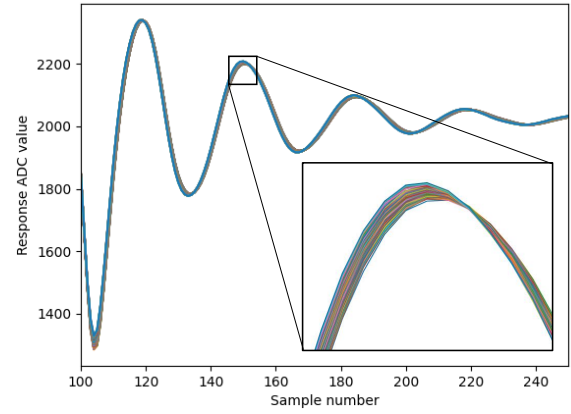

Figure 5. Shift of the sensing response frequency with the changing ink pressure. Each curve is done at a pressure varying between -5mBar and -25mBar with a resolution of 0,2mBar.

to get a single value for the printhead. This pressure range ensures that no meniscus breaks and no nozzle gets wet. These measurements do not give a correct absolute pressure because the pressure in the nozzle is not exactly the pressure set by the pressure regulator, but they do give the pressure variation based on a frequency variation.

Results

Figure 6 shows the correlation between the the response frequency and the static pressure.

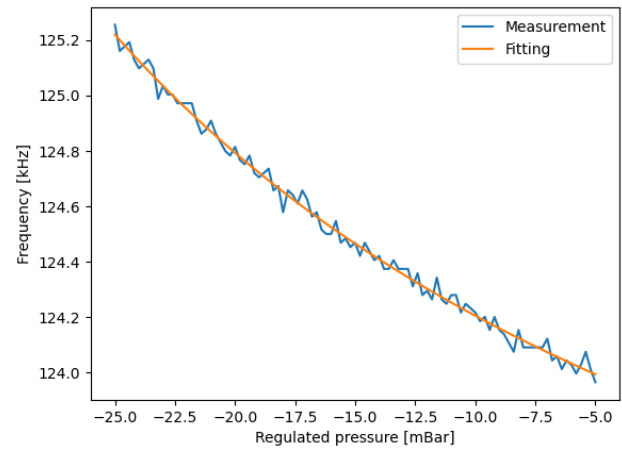

Figure 6. Measurement of the sensing response frequency in the jetting pressure range. The Fitting curve is of type $y = \frac{a}{x-h} + k$

The analysis of the tendency is done using a non-linear least squares with a curve of function $y = \frac{a}{x-h} + k$ giving in this case a fitting of:

$$f = \frac{a}{p-h} + k = \frac{109.2}{p+58.4} + 121.9 \quad (7)$$

The figure 8 shows the profile of one bank of the printhead and its 320 nozzles with a high flow of ink going through the ink manifold. This measure was done as a proof of concept of fluidic resistance measurement in the printhead. A lot of noise is still present in the measurements but they allow to see the tendency of the results. This result confirm that, for the jetting pressure range, the frequency is inversely proportional to the pressure.

As an example of application, the difference of pressure between the first and last nozzle allows to calculate the fluidic resistance of the manifold. The pressures indicated are not absolute pressure but difference of pressure relatively to a reference profile measured in static condition with no flow rate. The important information is the value of the pressure drop through the printhead. For a pressure difference of 250mBar set up in the ink system pressure regulator and ink flowing from nozzle 1 to 320

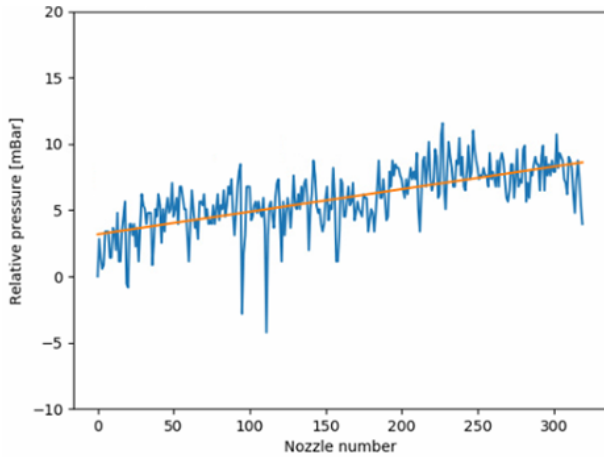

Figure 7. Pressure profile for one bank with 175ml/min of ink flow rate from nozzle 320 to nozzle 1

By applying a liner regression to the data, the tendency of the printhead pressure profile can be measured. This give a fluidic resistance for the manifold of:

$$R_{Manifold} = \frac{\Delta p}{Q} = \frac{5.44mBar}{175ml/min} = 186 * 10^6 \frac{Pa}{m^3/s} \quad (8)$$

Where:

- $R_{Manifold}$: Fluidic resistance of the manifold
- Δp : pressure drop through the printhead
- Q : Flow rate

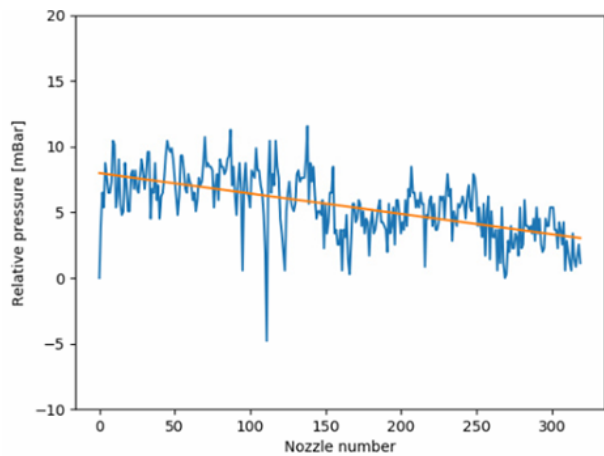

Figure 8. Pressure profile for one bank with 175ml/min of ink flow rate from nozzle 1 to nozzle 320

The same measure done in figure 8 with the pressure difference inverted gives a fluidic resistance of:

$$R_{Manifold} = \frac{\Delta p}{Q} = \frac{4.95mBar}{175ml/min} = 170 * 10^6 \frac{Pa}{m^3/s} \quad (9)$$

We can see that the results with the flow going in each directions are similar but not identicals. The measurements of fluidic resistance where done as a proof of concept and the precision could be greatly improved in an industrialised system.

Conclusion

In this study, a system was developed to monitor the self-sensing of a piezo-driven printhead. By isolating the amplification of the sensing signal from the piezo and adding a compensation capacitor, the noise of the measured sensing response was reduced, allowing small variations in frequency to be measured.

Using the circuit developed in a controlled environment, the experiments were able to correlate pressure variations with the frequency of the sensing response. The study also showed that the capabilities of the system allow the fluidic resistance of the ink manifold to be measured, based on the pressure drop across the head and the flow rate.

References

- [1] Charles K. Ntim, Sophia P. Ocran, and Richard Acquaye, "Digital textile printing: A new alternative to short-run textile printing in ghana," *International Journal of Technology and Management Research*, vol. 2, pp. 60–65, 3 2017.
- [2] San Kim, Jun Hyeok Choi, Dong Kee Sohn, and Han Seo Ko, "The effect of ink supply pressure on piezoelectric inkjet," *Micromachines*, vol. 13, 4 2022.
- [3] Herman Wijshoff, "The dynamics of the piezo inkjet printhead operation - sciencedirect," .
- [4] Kye Si Kwon, Yun Sik Choi, and Jung Kook Go, "Inkjet jet failures and their detection using piezo self-sensing," *Sensors and Actuators A: Physical*, vol. 201, pp. 335–341, 10 2013.
- [5] Dijkstra J. Fritz, *Design of Piezo Inkjet Print Heads.*, Wiley-vch edition.
- [6] "Ricoh mh5420/5440 product page," Accessed on 2023-11-30.
- [7] Kye-Si Kwon, "Methods for detecting air bubble in piezo inkjet dispensers," *Sensors and Actuators A*, vol. 153, pp. 50–56, June 2009.

Author Biography

Loïc Bullot holds a Master of Science in Electrical Engineering, specializing in embedded systems from the HES-SO in Switzerland (2023). During his studies he worked for one year part time at iPrint and for six month in the ATLAS group of the Lawrence National Berkeley Laboratory for his master thesis. He is now working full time as a Ra&D engineer in iPrint.

Mail: loic.bullot@hefr.ch

Carlos Chabert holds two bachelor's degrees in Mechanical Engineering (2013) and Electrical Engineering (2015) from the Jaume I University, two master's degrees in Electronic Systems Engineering, specialising in Digital Electronics (2016) from the Polytechnic University of Valencia, and another master's degree in Advanced and Applied Artificial Intelligence (2022) from the University of Valencia. In parallel with his studies, he worked full-time for 6 years as an electronics designer in a leading multinational company in the industrial sector of inkjet printing for large machines, which led him to join the self-sensing inkjet technology team at iPrint.

Mail: carlos.chabertull@hefr.ch